

INTRODUCTION

Thank you for choosing an HK Instruments DPT series differential pressure transmitter. The DPT series is intended for use in commercial environments. The DPT-2W series differential pressure transmitter provides a 4–20 mA loop output.

All DPT-2W series differential pressure transmitters are available with display and/or flow linear output.

APPLICATIONS

DPT-2W series devices are commonly used in HVAC/R systems for:

- fan, blower and filter monitoring
- pressure and flow monitoring
- valve and damper control
- pressure monitoring in cleanrooms

SPECIFICATIONS

Performance

Accuracy:

±1.5 % FS over operation temperature range:
-10...50 °C %/FS from highest pressure range (including: general accuracy, temperature drift, linearity, hysteresis, and repetition error)

Long term stability:

Typical 1 year: ±8 Pa; DPT-2W-2500

Thermal effects:

Temperature compensated across the full spectrum of capability.

Overpressure:

Proof pressure: 25 kPa

Burst pressure: 30 kPa

Zero point calibration:

Manual pushbutton

Response time:

4.0 s or 0.8 s, selectable

Technical Specifications

Media compatibility:

Dry air or non-aggressive gases

Measuring units:

Pa

Measuring element:

Piezoresistive

Environment:

Operating temperature: -10...50 °C

Storage temperature: -20...70 °C

Humidity: 0 to 95 % rH, non condensing

Physical

Dimensions:

Case: 90.0 x 95.0 x 36.0 mm

Weight:

150 g

Mounting:

2 each 4.3 mm screw holes, one slotted

Materials:

Case: ABS

Lid: PC

Duct connectors: ABS

Tubing: PVC

Protection standard:

IP54

Display: (Optional)

3 1/2 digit LCD display

Size: 45.7 mm W x 12.7 mm H

Electrical connections:

2 screw terminal block

Wire: 12–24 AWG (0.2–1.5 mm²)

Cable entry:

Strain relief: M16

Conduit knockout: 16 mm

Pressure fittings:

Male 5.0 mm and 6.3 mm

WARNING

- READ THESE INSTRUCTIONS CAREFULLY BEFORE ATTEMPTING TO INSTALL, OPERATE OR SERVICE THIS DEVICE.
- Failure to observe safety information and comply with instructions can result in PERSONAL INJURY, DEATH AND/OR PROPERTY DAMAGE.
- To avoid electrical shock or damage to equipment, disconnect power before installing or servicing and use only wiring with insulation rated for full device operating voltage.
- To avoid potential fire and/or explosion do not use in potentially flammable or explosive atmospheres.
- Retain these instructions for future reference.
- This product, when installed, will be part of an engineered system whose specifications and performance characteristics are not designed or controlled by HK Instruments. Review applications and national and local codes to assure that the installation will be functional and safe. Use only experienced and knowledgeable technicians to install this device.

Electrical

Voltage:

Circuit: 2-wire

Supply: 10–35 VDC

Supply (Current): 32 mA maximum

Output: 4–20 mA loop

Zero/Span output calibrated within ±0.08 mA

Maximum load = $\frac{\text{Supply} - 10 \text{ V}}{0,020 \text{ A}}$

Minimum load: 20 Ω

Power consumption: <1.2 W

Conformance

Meets requirements for CE marking:

EMC Directive 2014/30/EU

RoHS Directive 2011/65/EU

WEEE Directive 2012/19/EU

COMPANY WITH
MANAGEMENT SYSTEM
CERTIFIED BY DNV GL
= ISO 9001 = ISO 14001 =



SCHEMATICS

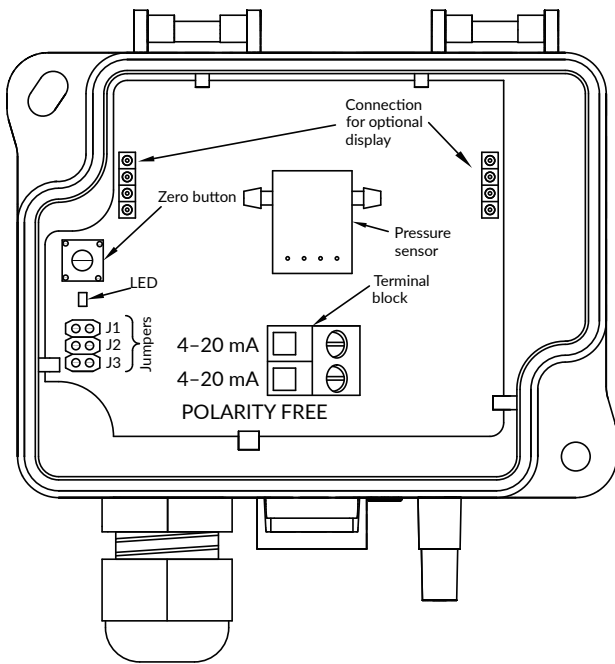

DIMENSIONAL DRAWINGS

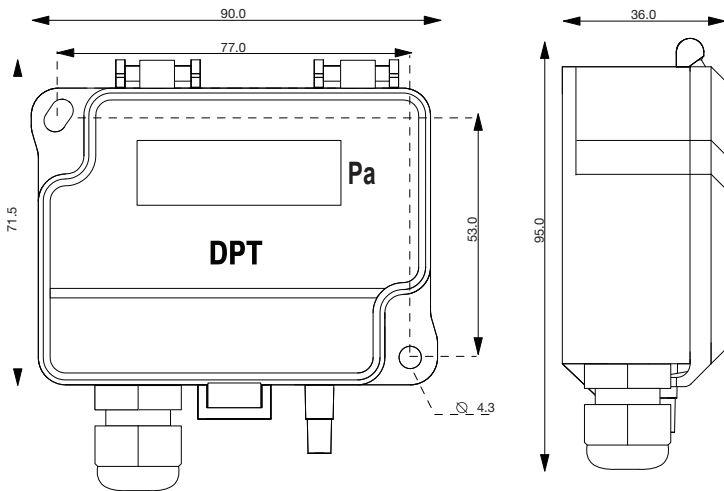

INSTALLATION

- 1) Mount the device in the desired location (see step 1).
- 2) Open the lid and route the cable through the strain relief and connect the wires to the terminal block(s) (see step 2).
- 3) The device is now ready for configuration.

⚠ WARNING! Apply power only after the device is properly wired.

STEP 1: MOUNTING THE DEVICE

- 1) Select the mounting location (duct, wall, panel).
- 2) Use the device as a template and mark the screw holes.
- 3) Mount with appropriate screws.

Figure 1a - Surface mounting

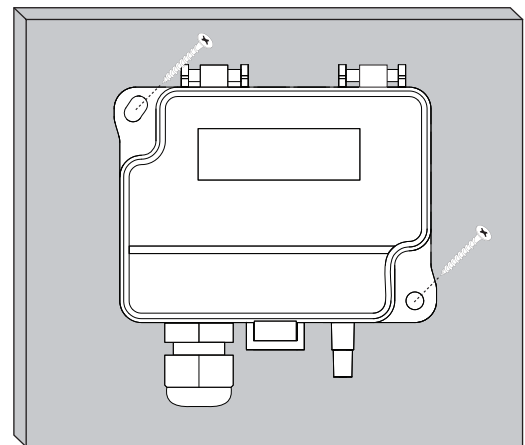

Figure 1b - Mounting orientation

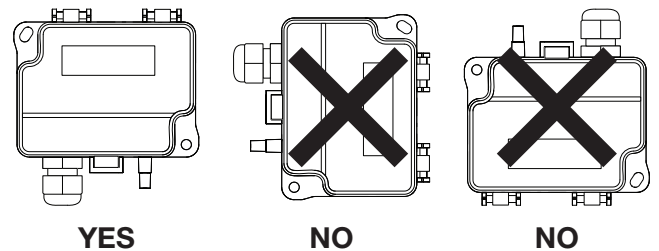
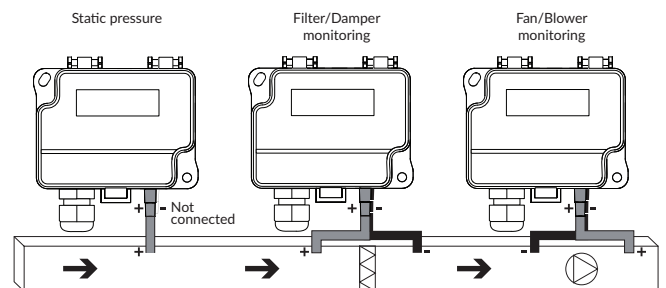

Figure 1c - Application connections



STEP 2: WIRING DIAGRAMS

For CE compliance, a properly grounded shielding cable is required.

- 1) Unscrew the strain relief and route the cable.
- 2) Connect the wires as shown in figure 2.
- 3) Tighten the strain relief.

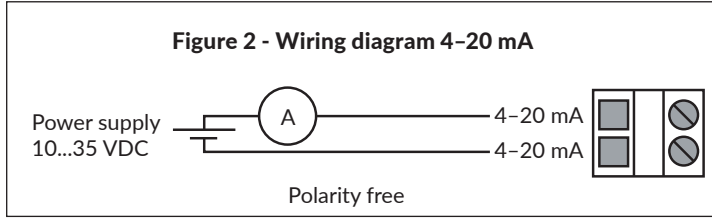

STEP 3: CONFIGURATION

- 1) Select the desired measurement range. (see step 4)
- 2) Select the desired response time. (see step 5)
- 3) Zero the device. (see step 6)
- 4) Connect the pressure tubes. Connect positive pressure to port labeled "+" and negative pressure to port "-".
- 7) Close the lid. The device is now ready to be used.

STEP 4: SELECTING THE MEASUREMENT RANGE

A. For R8 models

- 1) Find the required measurement range and determine the range number in the header of Chart 1.
- 2) Install jumpers on J1, J2 and J3 in device, as shown in Chart 2. (Grey colour indicates that a jumper is installed. Reference Figure 3 for jumper installation.)

Chart 1 - R8 ranges

Model DPT-2W-2500-R8

	Range 1	Range 2	Range 3	Range 4	Range 5	Range 6	Range 7	Range 8
Pa	-100...+100	0...100	0...250	0...500	0...1000	0...1500	0...2000	0...2500

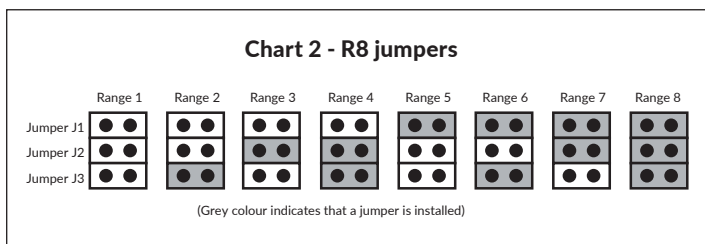

B. For R4 models

- 1) Find the required measurement range and determine the range number in the header of Chart 3.
- 2) Install jumpers on J2 and J3 in device, as shown in Chart 4. (Grey colour indicates that a jumper is installed. Reference Figure 3 for jumper installation.)

Chart 3 - R4 ranges

4-range models

	Range 1	Range 2	Range 3	Range 4
DPT-2W-1000-R4	0...250	0...500	0...750	0...1000
DPT-2W-3000-R4	0...750	0...1500	0...2250	0...3000
DPT-2W-5000-R4	0...1250	0...2500	0...3750	0...5000

SELECTING THE MEASUREMENT RANGE CONTINUED

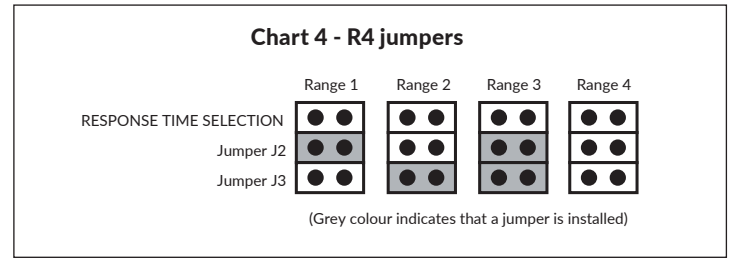

C. For R2 models

- 1) Find the required model and measurement range and determine the range number in the header of Chart 5.
- 2) Install jumpers on J2 and J3 in device, as shown in Chart 6. (Grey colour indicates that a jumper is installed. Reference Figure 3 for jumper installation.)

Chart 5 - R2 ranges

2-range models

	Range 1	Range 2	
DPT-2W-100-R2	0...50	0...100	Pa
DPT-2W-±100-R2	-50...50	-100...100	Pa
DPT-2W-250-R2	0...100	0...250	Pa
DPT-2W-500-R2	0...250	0...500	Pa
DPT-2W-1000-R2	0...500	0...1000	Pa
DPT-2W-2500-R2	0...1500	0...2500	Pa
DPT-2W-5000-R2	0...2500	0...5000	Pa

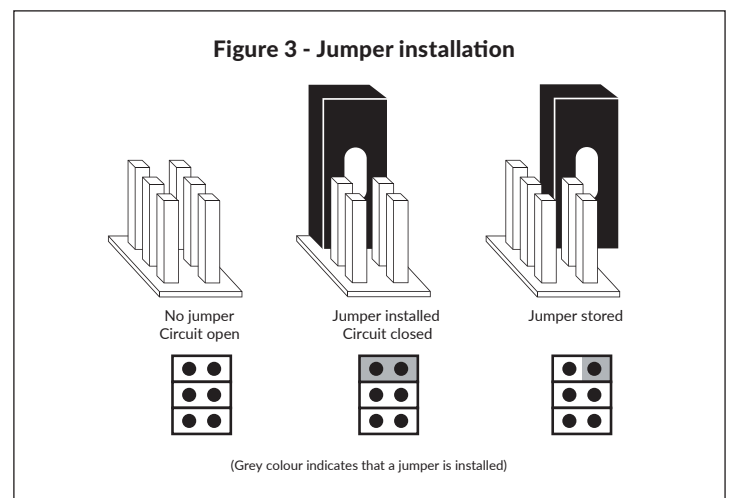
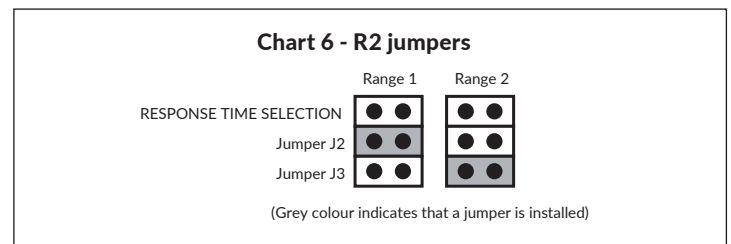

STEP 5: SELECTING THE RESPONSE TIME

A. For R8 model:

The response time affects how fast the transmitter reacts to changes in the system. The response time is the time the device takes to reach 63 % of the measured value. To smooth out unstable pressure fluctuations in airflow applications, select a longer response time.

Example:

Selected response time: 8.0 seconds

Result: Output signal achieves a new value in 20 seconds (Response time*5)

Use the zero button to change response time:

- 1) Push down and release the button quickly. LED emits 2 blinks. Device is set with 8.0 second response time.
- 2) Push down and release the button quickly again. LED emits 3 short blinks. Device is set with 0.8 second response time.

B. For R2 and R4 models

Use the jumper J1 to select the response time. Install jumper to J1 to set 0.8 s response time. Remove the jumper J1 to set 4 s response time. (See chart 7)

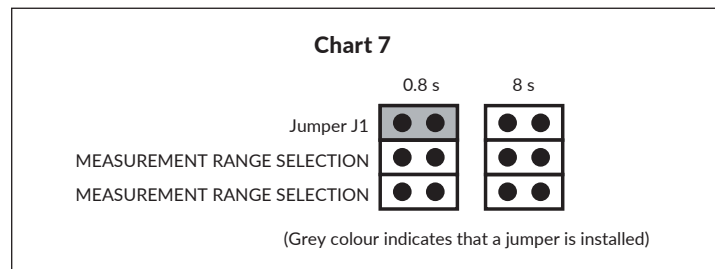

STEP 6: ZEROING THE DEVICE

The zero point should be adjusted via manual zeroing, one hour after installation and at least every 12 months during normal operations.

Manual zeroing:

- 1) Note: supply voltage must be connected at least one hour prior to zero point adjustment.
- 2) Disconnect both pressure tubes from the pressure ports labeled + and -.
- 3) Push the zero button at least 4 seconds until the LED light (red) shows one long blink. (see Figure 4)
- 4) The zeroing of the device will proceed automatically. Zeroing is complete when the LED turns off.
- 5) Reinstall the pressure tubes, ensuring the high pressure tube is connected to the port labeled +, and the low pressure tube is connected to the port labeled -.

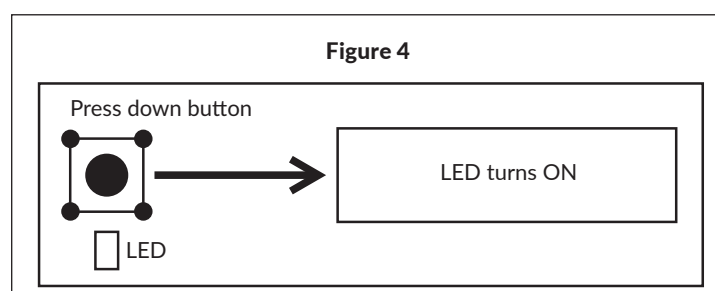

RECYCLING/DISPOSAL

The parts left over from installation should be recycled according to your local instructions. Decommissioned devices should be taken to a recycling site that specializes in electronic waste.



WARRANTY POLICY

The seller is obligated to provide a warranty of five years for the delivered goods regarding material and manufacturing. The warranty period is considered to start on the delivery date of the product. If a defect in raw materials or a production flaw is found, the seller is obligated, when the product is sent to the seller without delay or before expiration of the warranty, to amend the mistake at his/her discretion either by repairing the defective product or by delivering free of charge to the buyer a new flawless product and sending it to the buyer. Delivery costs for the repair under warranty will be paid by the buyer and the return costs by the seller. The warranty does not comprise damages caused by accident, lightning, flood or other natural phenomenon, normal wear and tear, improper or careless handling, abnormal use, overloading, improper storage, incorrect care or reconstruction, or changes and installation work not done by the seller or his/her authorized representative. The selection of materials for devices prone to corrosion is the buyer's responsibility, unless otherwise is legally agreed upon. Should the manufacturer alter the structure of the device, the seller is not obligated to make comparable changes to devices already purchased. Appealing for warranty requires that the buyer has correctly fulfilled his/her duties arisen from the delivery and stated in the contract. The seller will give a new warranty for goods that have been replaced or repaired within the warranty, however only to the expiration of the original product's warranty time. The warranty includes the repair of a defective part or device, or if needed, a new part or device, but not installation or exchange costs. Under no circumstance is the seller liable for damages compensation for indirect damage.