



Pressure switch



## Relative pressure switch

### Type 521

The compact type 521 pressure switch is based upon the Huba Control developed thick film technology where the pressure measuring cell is fully welded.

Switching points set in factory are available both N/C and N/O function. Various electrical and pressure connections are available to suit given applications.

## Pressure range

0 ... 2.5 – 600 bar

- + Compact, rugged construction
- + Welded without sealing parts
- + Saving time by quick cable mounting by the customer with swift connector
- + Large selection of connections available

## Technical overview

### Pressure range

Relative 0 ... 2.5 – 600 bar

### Operating conditions

Medium	Liquids, gases and refrigerants (incl. ammonia)	
Temperature	Medium	-40 ... +135 °C
	Ambient	-30 ... +85 °C
	Storage	-50 ... +100 °C
Tolerable overload	≤ 6 bar	5 x FS
	> 6 bar	3 x FS (max. 1500 bar)
Rupture pressure	≤ 6 bar	10 x FS
	> 6 bar	6 x FS (max. 2500 bar)

### Materials

Pressure Connection	Stainless steel 1.4404 / AISI 316L (inside thread Schrader 1.4305 / AISI 303 only)	
Plug accommodation	Polyarylamide 50% GF UL 94 V-0	
Materials in contact with medium	Pressure connection	Stainless steel 1.4404 / AISI 316L (inside thread Schrader 1.4305 / AISI 303 only)
	Sensor	Stainless steel

### Electrical overview

Output	Semiconductor (open collector)	
Switching contact	High-Side Switch (PNP)	N/C contact or N/O contact
Switch load	High-Side Switch (PNP) max. 200 mA	
Power supply	7 ... 33 VDC	
Current consumption	< 4 mA	
Insulation voltage	500 VDC	

### Dynamic response

Response time	< 2 ms, 1 ms typ.
Load cycle	< 100 Hz

### Adjustment of switching points (factory set)

Upper switching point	8 ... 100% fs
Lower switching point	5 ... 97% fs
Hysteresis	≥ 3 % fs

### Electrical connection

	Protection standard	Protection class
Swift connector with or without cable 1.5 m	IP 67	III
Connector M12x1	IP 67	III

### Pressure connection

Inside thread	$\frac{7}{16}$ - 20 UNF	without or with Schrader
	G $\frac{1}{4}$	with O-Ring seal FPM (-30 ... +135 °C)
	$\frac{1}{2}$ - 14 NPT	≤ 60 bar
Outside thread	M20x1,5	sealed at front and manometer (combi)
	$\frac{7}{16}$ - 20 UNF	sealing cone 45°
	$\frac{1}{4}$ - 18 NPT	
	G $\frac{1}{4}$	sealed at back DIN EN ISO 1179-2 with Profile seal ring in FPM (-30 ... +135 °C)
	R $\frac{1}{4}$	EN 10226
	G $\frac{1}{2}$	sealed at back and manometer (combi) with Profile seal ring in FPM (-30 ... +135 °C)
	G $\frac{1}{2}$	sealed at front

### Installation arrangement

Unrestricted

### Tests / Admissions

Electromagnetic compatibility	CE conformity acc. EN 61326-2-3 and 50121-3-2
Shock acc. IEC 68-2-27	100 g, 11 ms half sine wave, all 6 directions, free fall from 1 m on concrete (6x)
Constant shock acc. IEC 68-2-29	40 g for 6 ms, 1000x all 3 directions
Vibration acc. IEC 68-2-6	20 g, 15 ... 2000 Hz, 15 ... 25 Hz with amplitude ± 15 mm, 1 Octave/min. all 3 directions, 50 constant load
UL	ANSI/UL 61010-1 acc. E325110
EAC	

### Weight

~ 90 g

### Packaging (Please state on order)

Single packaging in cardboard	accessories integrated
Multiple packaging in cardboard (25 pcs)	

## Accuracy

Parameter		Unit	
Switching points <sup>1)</sup>		% fs	± 0.5
Resolution		% fs	0.1
Thermal characteristic <sup>2)</sup>	max.	% fs/10K	± 0.2
Long term stability acc. IEC EN 60770-1	max.	% fs	± 0.25

Test conditions: 25°C, 45% RH, power supply 24 VDC

<sup>1)</sup> typ. ; max. 1.0% fs (incl. hysteresis and repeatability)

<sup>2)</sup> -15 ... 85 °C

		1	2	3	4	5	6	7	8	9	10	11	
<b>Order code selection table in bar</b>		521.	X	X	X	X	X	X	X	X	X	X	
<b>Pressure range <sup>1)</sup></b>	0 ... 2.5 bar	9	1	4									
	0 ... 4 bar	9	1	5									
	0 ... 6 bar	9	1	7									
	0 ... 10 bar	9	3	0									
	0 ... 16 bar	9	3	1									
	0 ... 25 bar	9	3	2									
	0 ... 40 bar	9	3	3									
	0 ... 60 bar	9	4	0									
	0 ... 100 bar	9	4	1									
	0 ... 160 bar	9	4	2									
	0 ... 250 bar	9	4	3									
	0 ... 400 bar	9	5	4									
	0 ... 600 bar	9	5	5									
<b>Version</b>	standard				S	0							
	for oxygen applications				S	1							
<b>Switching contact</b>	Contact N/O High-Side-Switch PNP						1						
	Contact N/C High-Side-Switch PNP						2						
<b>Electrical connection</b>	Swift connector without cable							0					
	Connector M12x1 <sup>2)</sup>							3					
	Swift connector with cable 1.5 m							L					
						0			0	0	N		
<b>Pressure connection <sup>3)</sup></b>	Inside thread	7/16"-20 UNF sealing cone with Schrader							K		1		
		7/16"-20 UNF											
		G 1/4 with O-Ring seal FPM								1		1	
		1/2 -14 NPT (≤ 60 bar)								D		1	
	Outside thread	M20x1.5 sealed at front and manometer (combi)								E		1	
		7/16"-20 UNF sealing cone								2		1	
		1/4 -18 NPT								3		1	
		G 1/4 sealed at back DIN EN ISO 1179-2 with Profile seal ring in FPM								4		1	
		R 1/4 acc. to EN 10226								7		1	
		G 1/2 sealed at back and manometer with Profile seal ring in FPM								8		1	
G 1/2 sealed at front								9		1			
<b>Pressure tip orifice <sup>2)</sup></b>	without (Inclusive pressure tip orifice from 100 bar on)									0			
	with									2			
<b>Material</b>	Stainless steel 1.4305 / AISI 303										N		
<b>pressure connection</b>	Stainless steel 1.4404 / AISI 316L										1		
<b>Switching points</b>	Indicate W and state switching points on order (e.g.: W100/60bar)											W	

		1	2	3	4	5	6	7	8	9	10	11	
<b>Order code selection table in psi</b>		521.	X	X	X	X	X	X	X	X	X	X	
<b>Pressure range <sup>1)</sup></b>	0 ... 30 psi	9	B	4									
	0 ... 60 psi	9	B	5									
	0 ... 100 psi	9	B	7									
	0 ... 200 psi	9	C	1									
	0 ... 300 psi	9	C	2									
	0 ... 500 psi	9	C	3									
	0 ... 750 psi	9	D	0									
	0 ... 1000 psi	9	D	1									
	0 ... 2000 psi	9	D	2									
	0 ... 3000 psi	9	D	3									
	0 ... 5000 psi	9	E	4									
	0 ... 7500 psi	9	E	5									
	<b>Version</b>	standard				S	0						
for oxygen applications					S	1							
<b>Switching contact</b>	Contact N/O High-Side-Switch PNP						1						
	Contact N/C High-Side-Switch PNP						2						
<b>Electrical connection</b>	Swift connector without cable							0					
	Connector M12x1 <sup>2)</sup>							3					
	Swift connector with cable 1.5 m							L					
						0			0	0	N		
<b>Pressure connection <sup>3)</sup></b>	Inside thread	7/16"-20 UNF sealing cone with Schrader								K		1	
		7/16"-20 UNF											
		G 1/4 with O-Ring seal FPM									1		1
		1/2 -14 NPT (≤ 870 psi)									D		1
	Outside thread	M20x1.5 sealed at front and manometer (combi)									E		1
		7/16"-20 UNF sealing cone									2		1
		1/4 -18 NPT									3		1
		G 1/4 sealed at back DIN EN ISO 1179-2 with Profile seal ring in FPM									4		1
		R 1/4 acc. to EN 10226									7		1
		G 1/2 sealed at back and manometer with Profile seal ring in FPM									8		1
G 1/2 sealed at front									9		1		
<b>Pressure tip orifice <sup>2)</sup></b>	without (Inclusive pressure tip orifice from 2000 psi on)									0			
	with									2			
<b>Material</b>	Stainless steel 1.4305 / AISI 303										N		
<b>pressure connection</b>	Stainless steel 1.4404 / AISI 316L										1		
<b>Switching points</b>	Indicate W and state switching points on order (e.g.: W1000/400psi)											W	

<sup>1)</sup> Other pressure ranges on request

<sup>2)</sup> Delivery without female connector

<sup>3)</sup> Other pressure connections on request

Order code selection table in MPa		1	2	3	4	5	6	7	8	9	10	11	
		521.	X	X	X	X	X	X	X	X	X	X	
Pressure range <sup>1)</sup>	0 ... 0.25 MPa	9	G	4									
	0 ... 0.4 MPa	9	G	5									
	0 ... 0.6 MPa	9	G	7									
	0 ... 1 MPa	9	H	0									
	0 ... 1.6 MPa	9	H	1									
	0 ... 2.5 MPa	9	H	2									
	0 ... 4 MPa	9	H	3									
	0 ... 6 MPa	9	K	0									
	0 ... 10 MPa	9	K	1									
	0 ... 16 MPa	9	K	2									
0 ... 25 MPa	9	K	3										
0 ... 40 MPa	9	L	4										
0 ... 60 MPa	9	L	5										
Version	standard					S	0						
	for oxygen applications					S	1						
Switching contact	Contact N/O High-Side-Switch PNP							1					
	Contact N/C High-Side-Switch PNP							2					
Electrical connection	Swift connector without cable								0				
	Connector M12x1 <sup>2)</sup>								3				
	Swift connector with cable 1.5 m								L				
Pressure connection <sup>3)</sup>	Inside thread	$\frac{7}{16}$ -20 UNF sealing cone with Schrader					0			0	0	N	
		$\frac{7}{16}$ -20 UNF								K		1	
		G $\frac{1}{4}$ with O-Ring seal FPM									1		1
		$\frac{1}{2}$ -14 NPT ( $\leq 6$ MPa)									D		1
		M20x1.5 sealed at front and manometer (combi)									E		1
	Outside thread	$\frac{7}{16}$ -20 UNF sealing cone									2		1
		$\frac{1}{4}$ -18 NPT									3		1
		G $\frac{1}{4}$ sealed at back DIN EN ISO 1179-2 with Profile seal ring in FPM									4		1
		R $\frac{1}{4}$ acc. to EN 10226									7		1
		G $\frac{1}{2}$ sealed at back and manometer with Profile seal ring in FPM									8		1
G $\frac{1}{2}$ sealed at front									9		1		
Pressure tip orifice <sup>2)</sup>	without (Inclusive pressure tip orifice from 10 MPa on)									0			
	with									2			
Material	Stainless steel 1.4305 / AISI 303											N	
pressure connection	Stainless steel 1.4404 / AISI 316L											1	
Switching points	Indicate W and state switching points on order (e.g.: W10/5MPa)											W	

### Accessories (supplied loose) Order number

Swift connector	117312
Corner-wire box for connector M12x1 with cable 2.0 m	114604
Corner-wire box for connector M12x1	106975
Straight-wire box for connector M12x1	114570
Straight-wire box for connector M12x1 with cable 2.0 m	114605
Mounting bracket with screw	118716
Heat sink with outside thread G $\frac{1}{2}$ sealed at front - inside thread G $\frac{1}{2}$	105631
Heat sink with outside thread G $\frac{1}{2}$ sealed at front - inside thread G $\frac{1}{4}$	105073
Heat sink with outside thread G $\frac{1}{4}$ sealed at front - inside thread G $\frac{1}{4}$	105074
Calibration certificate (at factory set switching points)	104551

Mounting bracket

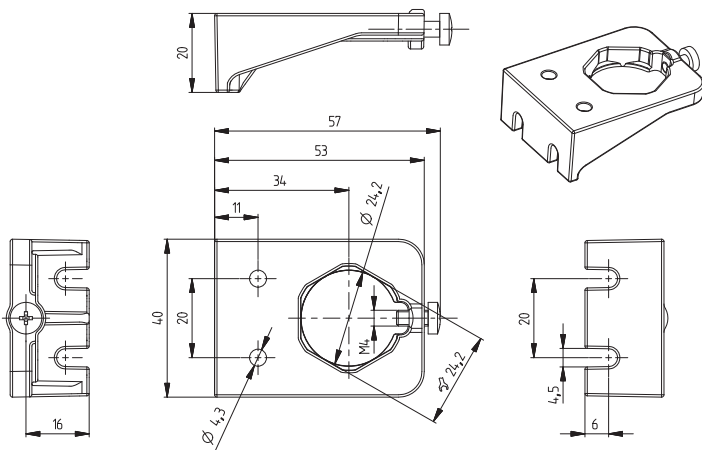

Heat sink

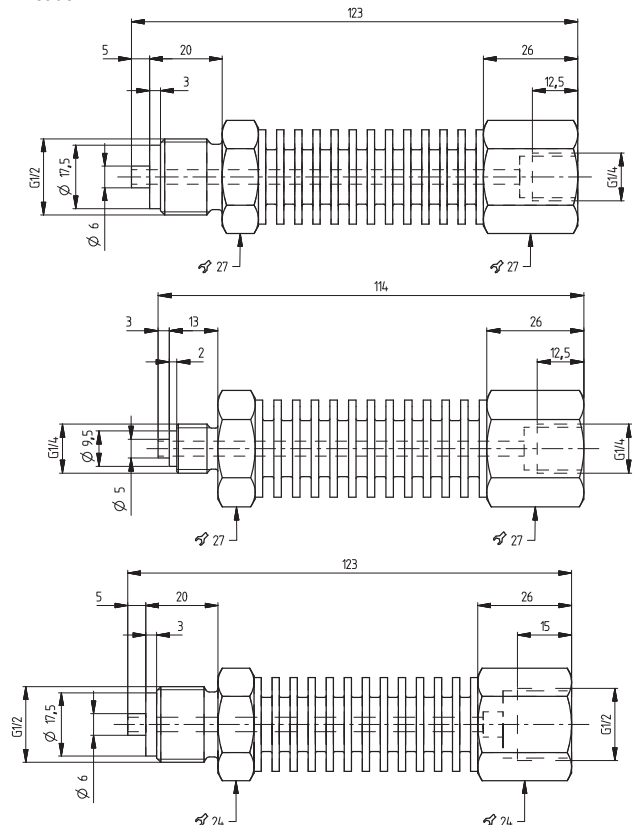

<sup>1)</sup> Other pressure ranges on request

<sup>2)</sup> Delivery without female connector

<sup>3)</sup> Other pressure connections on request

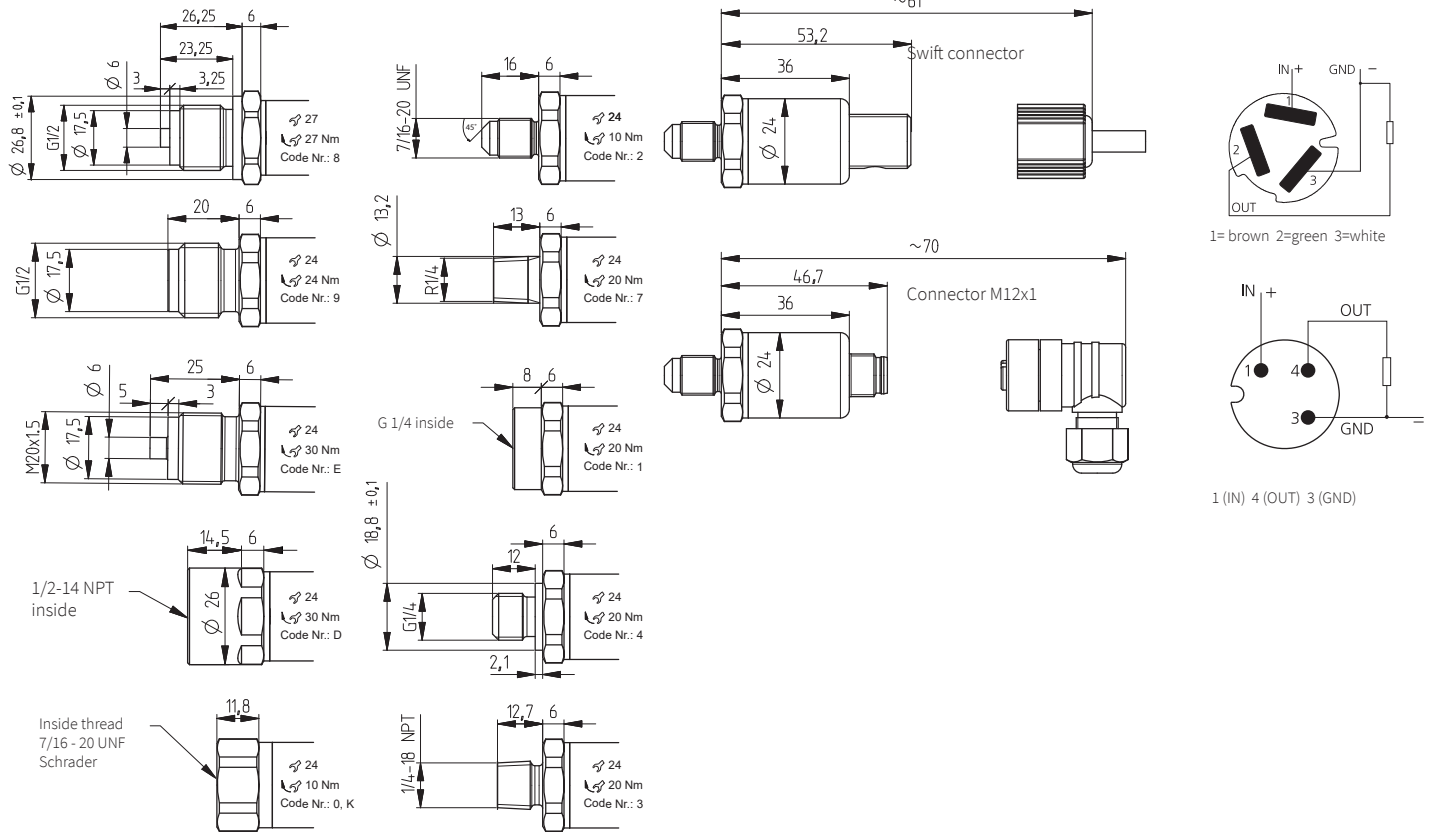

Function

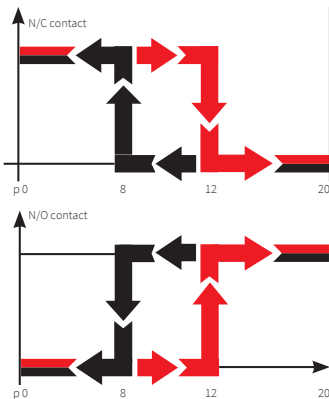

**N/C contact:** When pressure is applied ( $p_0 \rightarrow p_{max}$ ) the switch will disconnect the applied load as soon as the upper switching point is reached. As the pressure falls ( $p_{max} \rightarrow p_0$ ) the switch will connect the load as soon as the lower switching point is reached.

**N/O contact:** When pressure is applied ( $p_0 \rightarrow p_{max}$ ) the switch will connect the applied load as soon as the upper switching point is reached. With a fall in pressure ( $p_{max} \rightarrow p_0$ ) the switch will disconnect the load as soon as the lower switching point is reached.

Example:  $p_s$  20 bar  
 Upper switching point 12 bar  
 Lower switching point 8 bar  
 max. switching load 100 mA

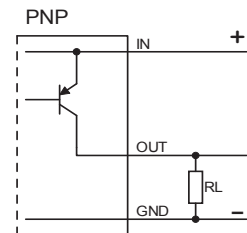



株式会社 **クローネ**

■カタログに掲載してある製品の色は印刷インキの関係上、実際とは異なる場合があります。  
■製品のデザイン、仕様等などは、予告なく変更する場合があります。

本 社：〒124-0023 東京都葛飾区東新小岩3丁目9番6号 TEL: (03) 3695-5431 / FAX: (03) 3695-5698  
大阪支店：〒530-0054 大阪市北区南森町2-2-9(南森町八千代ビル7F) TEL: (06) 6361-4831 / FAX: (06) 6361-9360  
e-mail: sales-tokyo@krone.co.jp URL: <https://www.krone.co.jp>

[www.hubacontrol.com](http://www.hubacontrol.com)

