

# iLEL GAS SENSOR

002707

Issue 3

## Combustible Gases and Vapours (LEL) Sensor Intelligent Series Gas Sensor (iseries)

### DOCUMENT PURPOSE

The purpose of this document is to present the performance specification of the intelligent iLEL75 combustible gases and vapours gas sensor. This document should be used in conjunction with the Product Safety Datasheet (PSDS 22). For guidance on the safe use of the sensor, please refer to the Communication Protocol (SDCS) and Sensor Mounting Application Note.



### PORTFOLIO

Compact, digital and intelligent gas sensors, iseries sensors are precalibrated, interchangeable and feature digital traceability. These sensors are rated for longer life and are designed to operate in extreme environmental conditions.



Combustible Gases and Vapours (LEL) Sensor: **iLEL**

### Part Numbers:

PM 979-600D-CIT (for iLEL75);  
PM 989-600D-CIT (for iLEL75C);  
PM 999-600D-CIT (for iLEL75M)



### 2 YEAR WARRANTY

(24 months from date of despatch)

## FEATURES AND BENEFITS

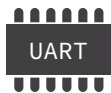

### Digital interface –

The sensor has a UART protocol to communicate with the instrument with chip select option as described in the Communication Protocol (SDCS)



### Interchangeable –

All intelligent sensors have the same dimensions and communication protocol. All sensors in the range will work with a supply voltage from 3.1 V to 3.3 V



### Digital traceability –

Sensors contain the following data: serial number, manufacturing date, and gas type for quick and easy identification of the sensor



### Pre-calibrated –

Sensors will be calibrated during manufacturing and calibration data is written in the sensor. Sensor will output gas concentration when interrogated by instrument



### Compact form factor

### Five-year life

### RoHS compliant



### OEM lock –

Sensors have two levels of lock codes. The first one is an OEM specific code programmed in during manufacture and cannot be modified. This lock code is provided by the OEM. Instrument can check if the sensor has the unique code – if not the instrument can refuse the sensor. The second level of lock code is left blank and can be updated by OEM/Partners during sensor integration into the instrument as needed



### Designed to meet global performance standards

**ATEX and IEC Ex Certified** per EN IEC 60079-0, EN IEC 60079-1, EN IEC 60079-11 and EN 50303

**UL Recognized for US and Canada** in File E180262. Consult page 4 and 5 for full details

TABLE 1. LEL SENSOR VARIANTS

SENSOR	iLEL75	iLEL75C	iLEL75M
<b>Target Gas</b>	Combustible gases and vapours	Combustible gases and vapours up to C6	Methane and hydrogen
<b>Inboard Filter</b>	To remove H <sub>2</sub> S	To remove H <sub>2</sub> S	To remove H <sub>2</sub> S
<b>Additional Filter</b>	None	Silica filter to improve silicone resistance	Carbon cloth filter to improve silicone resistance
<b>Catalogue Listings</b>	PM979-600D-CIT	PM989-600D-CIT	PM999-600D-CIT

# INTELLIGENT SERIES GAS SENSORS (iSERIES) iLEL SERIES

**TABLE 2. TECHNICAL SPECIFICATIONS**

MEASUREMENT	
<b>Operating Principle</b>	Catalytic Oxidation
<b>Range</b>	0 % to 100 % LEL
<b>Inboard Filter Capacity</b>	1000 ppm hr minimum
<b>Poison Resistance</b>	Resistant to H <sub>2</sub> S poisoning Superior silicone resistance
<b>Response Time*</b>	<20 seconds to CH <sub>4</sub>
<b>Overload</b>	100 % LEL
<b>Output</b>	% LEL target gas output Compensated for temperature
<b>Measurement Interval</b>	1 sample per second (1 Hz)
<b>Linearity*</b>	Linear up to 5 % vol. CH <sub>4</sub>
<b>Measurement Accuracy</b>	5 % LEL
<b>Resolution</b>	1 % LEL
<b>Dead Band</b>	Configurable
<b>Warm-up Time</b>	15 seconds
<b>Serial Communication</b>	UART with Chip Select
ENVIRONMENTAL	
<b>Operating Humidity Range</b>	0 to 95 % RH (non-condensing)
<b>Operating Pressure Range</b>	600 mbar to 1200 mbar
<b>Operating Temperature Range</b>	-20°C to 60°C** ** Can be operated from -40°C to -20°C, see characterisation note for details.
<b>Flow Rate</b>	Typical: 200 ml/min when using recommended gassing hood. (Consult iSeries Sensor Mounting Application Note.)
LIFETIME	
<b>Long-Term Output Drift*</b>	<3 % signal per month
<b>Long-Term Baseline Drift</b>	<5 % LEL <sub>methane</sub> per month
<b>Expected Operating Life</b>	5 years in air
PHYSICAL CHARACTERISTICS	
<b>Weight</b>	<6 g
<b>Contact Material</b>	Gold plated
<b>O-Ring Material</b>	FKM60 ±5 shore A
<b>Outer Plastic Body Material</b>	PPS Fortron 1140L4

\* Specifications are valid at 20°C, 50% RH, and 1013 mBar using Honeywell recommended circuitry. Performance characteristics outline the performance of sensors supplied within the first three months. Output signal can drift below the lower limit over time.

## Product Dimensions

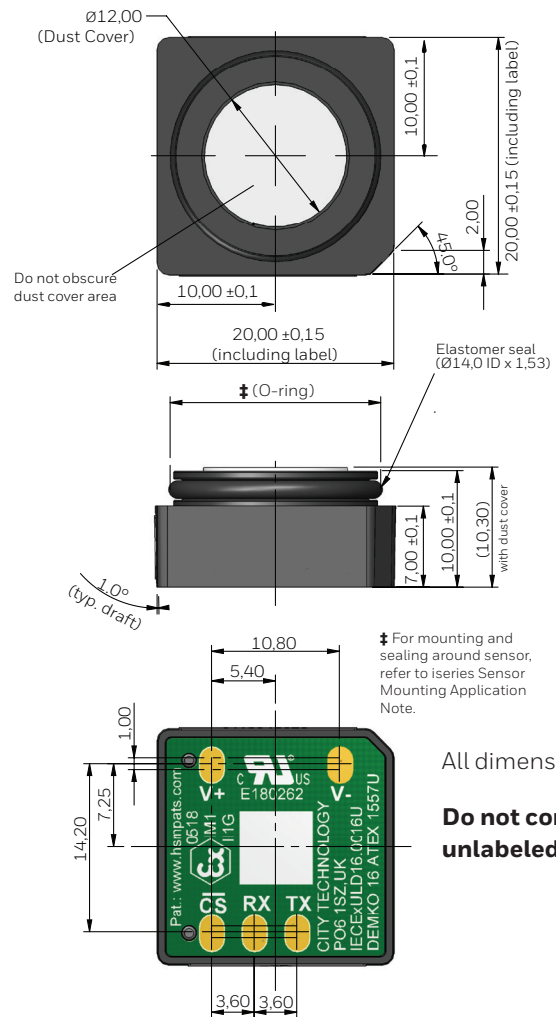

All dimensions in mm

**Do not connect to unlabeled pins.**

**TABLE 3. ELECTRICAL SPECIFICATIONS**

	Min.	Max.	Typ.	Unit
<b>Supply Voltage (Vdd)</b>	3.1	3.3	3.2	Vdc
<b>Voltage on any pin</b>	0	3.3	-	Vdc
<b>Current: at stand-by mode (sleep mode)</b>	0.82	1.4	1.4	mA
<b>Current: at active mode</b>	76	90	80	mA
<b>Power consumption at work mode</b>	235.6	297	256	mW
<b>Start-up time</b>	-	30	-	s

For compatibility with the whole iSeries range, the supply voltage should be between 3.1 V and 3.3 V.

**TABLE 4. PINOUT**

Pin	Description
<b>+V</b>	Positive power supply
<b>-V</b>	Ground
<b>Rx</b>	Data transmitted from instrument to sensor
<b>Tx</b>	Data transmitted from sensor to instrument
<b>CS</b>	Chip Select

# INTELLIGENT SERIES GAS SENSORS (iSERIES) iLEL SERIES

**TABLE 5. iLEL PARAMETERS**

iLEL parameters	Default Values	Configurable Range	Customisable: Implemented by Honeywell (Non-configurable through the communication protocol)	Configurable: The parameter can be changed through the communication protocol by users	Notes
OEM Lock	OEM code (First layer)	Password is customisable.* <b>(NoLock</b> will be set by default in case the OEM lock is not required)	No more than 6 characters (ASCII format)	✓	* OEM code will be set by Honeywell during sensor manufacturing. Code to be provided by OEM
	Partner code (Second layer)	-	No more than 6 characters (ASCII format)	✓	Once this code has been set by user, it is not possible to change it
User Factor	User factor 0: 100 User factor 1: 95 UF 2-3: Reserved UF 4-9: Customisable  User factors can be added to include auto-compensation for using different membranes or instruments	10 allocated slots ----- 2 user factors are already implemented (no additional membrane and with recommended membrane), 2 are reserved and the remaining 6 can be customised	✓*	✓**	* User factor 0 and 1 programmed into the sensor during manufacturing. Additional User Factors can be added to the selectable list during the manufacturing process. This user factor has to be provided by the user. ** Users can select the desired user factor from the selectable list
Unit of Measure	% LEL			✓	The gas concentration can be configured to measure either %LEL or %VOL
Calibration	Zero (clean air)	0 % LEL		✗	Calibration is performed at two points throughout the operating range of the sensor. The calibration points are defined by the zero and span values. The zero value represent the response of the sensor in clean air
	Span (target gas)	50 % LEL		✓	Span is the calibration point that is done in the presence of the target gas. The span concentration can be configured through the communication protocol. The span gas is 50 %LEL, or 2.5 %v/v methane, as per standard EN 50054
Alarms	Low	10 % LEL	Limit LOW lower: 3 Limit LOW upper: 60	✓	
	High	20 % LEL	Limit HIGH lower: 3 Limit HIGH upper: 60	✓	
Predictive calibration	<b>The alarm will be flagged when the countdown reaches 0</b>				
	Countdown timer (Cal due days)	180 days		✓	The countdown restarts when the sensor is calibrated. No predictive element for LEL
Target Gas		CH <sub>4</sub>		✓	The sensor can be configured to measure different target gases. Including CH <sub>4</sub> , C <sub>4</sub> H <sub>10</sub> , H <sub>2</sub> , C <sub>5</sub> H <sub>12</sub> , C <sub>3</sub> H <sub>8</sub>
Calibration Gas		CH <sub>4</sub>		✓	The sensor can be calibrated with the different gases (CH <sub>4</sub> , C <sub>4</sub> H <sub>10</sub> , H <sub>2</sub> , C <sub>5</sub> H <sub>12</sub> , C <sub>3</sub> H <sub>8</sub> ). It is recommended to calibrate with the target gas
End of Life	Countdown timer	1825 days		✗	The countdown timer is set for 1825 days, i.e. 5 years. No predictive element for LEL
Deadband	Active by default	✓		✓	With the deadband enabled the sensor will read zero until the concentration exceeds the deadband value. Is normally used to prevent measurement oscillations. This function can be configured to different limits
	Incoming	1 % LEL	Whole measurement range	✓	Incoming: As the reading decays down it will read zero once it has fallen below the incoming threshold
	Outgoing	3 % LEL	Incoming ≤ Outgoing	✓	Outgoing: As the reading increases it will read zero until it exceeds the outgoing threshold
Bump Due Days		1 day		✓	A bump test is a brief exposure of the sensor to the target gas. The test has the objective of verifying that the sensor responds and the instrument acts accordingly. The sensor will tell the user when the bump interval has been exceeded
Compliance Standard		EN 50054			The compliance standard measurement can be changed from EN 50054 to EN 60079-20-1

# INTELLIGENT SERIES GAS SENSORS (iSERIES)

## iLEL SERIES

**TABLE 6. INTRINSIC SAFETY**

<p><b>Applicable Standards</b></p>	<ul style="list-style-type: none"> <li>• UL 913, Intrinsically Safe Apparatus and Associated Apparatus for Use in Class I, II, and III, Division 1, Hazardous (Classified) Locations, Eighth Edition - Revision Date 2019/03/11</li> <li>• UL 508, Industrial Control Equipment Edition 18 - Revision Date 2018/03/30. CSA C22.2 NO. 14, Industrial Control Equipment Revision Date 2018/1/1</li> <li>• UL 60079-0, Electrical Apparatus for Explosive Atmospheres - Part 0: General Requirements, Seventh Edition - Issue Date 2019/03/26</li> <li>• UL 60079-1, Electrical Apparatus for Explosive Gas Atmospheres - Part 1: Equipment Protection by Flameproof Enclosures, Seventh Edition - Revision Date 2015/09/18</li> <li>• UL 60079-11, Electrical Apparatus for Explosive Atmospheres - Part 11: Intrinsic Safety "ia", Sixth Edition - Revision Date 2018/09/14.</li> <li>• CAN/CSA-C22.2 No. 157-92, Intrinsically Safe and Non-incendive Equipment for Use in Hazardous Locations - Edition 3 - Revision Date 2003/06/01</li> <li>• CSA C22.2 NO. 60079-0 Explosive Atmospheres - Part 0: Equipment - General Requirements Edition 4 - Issue Date 2019/02/01</li> <li>• CSA C22.2 NO. 60079-1:16 Electrical Apparatus for Explosive Gas Atmospheres - Part 1: Flameproof enclosures "d" - Edition 3 - Issue date 2016/05/01</li> <li>• CSA C22.2 NO. 60079-11:14 Explosive Atmospheres - Part 11: Equipment Protection By Intrinsic Safety "I"- Edition 2 - Issue Date 2014/02/01</li> <li>• IEC 60079-0 Explosive atmospheres - Part 0: Equipment - General requirements Edition 7 Revision Date 2017</li> <li>• IEC 60079-1 Electrical Appartus for Explosive Gas Atmospheres - Part 1: Flame-Proof Enclosures "D" Edition 7 Issue Date 06/2014</li> <li>• IEC 60079-11 Explosive Atmospheres - Part 11: Equipment Protection by Intrinsic Safety "I" Edition 6 Issue Date 06/2011</li> <li>• CENELEC EN IEC 60079-0 Explosive Atmospheres - Part 0: Equipment - General Requirements Issue Date 07/22/2018</li> <li>• CENELEC EN 60079-1 Explosive Atmospheres - Part 1: Equipment Protection by Flameproof Enclosures "D" Issue Date 10/2014</li> <li>• CENELEC EN 60079-11 Explosive Atmospheres - Part 11: Equipment Protection by Intrinsic Safety "I" Issue Date 02/03/2012</li> <li>• CENELEC EN 50303 GROUP I, Category M1 Equipment Intended to Remain Functional in Atmospheres Endangered by Firedamp and/or Coal Dust Edition Issue Date 07/2000</li> </ul>
------------------------------------	--

# INTELLIGENT SERIES GAS SENSORS (iSERIES)

## iLEL SERIES

**TABLE 7. APPROVALS AND STANDARDS**

	UL File Number	E 180262
	Certificate Numbers	DEMKO 16 ATEX 1557U IECEX ULD 16.0016U
	ATEX Marking	0518  IM1 II1G
<b>Protection Concept Markings</b>	ATEX/IEC Ex Marking	Ex da ia I Ma Ex da ia IIC Ga
	UL Marking	Division 1, Class I, Groups A, B, C, D Class I, Zone 0, AEx da ia IIC
<b>Electrical data</b>	iLEL75X	Rated voltage: 3.2 V Rated current: 90 mA Rated power: 297 mW
	iLEL75X	<b>Intrinsically safe specifications</b> U <sub>i</sub> = 5.88 V I <sub>i</sub> = 1.1 A P <sub>i</sub> = 1.2 W L <sub>i</sub> = 0 μH C <sub>i</sub> = 8.38 μF

## WARRANTY/REMEDY

Honeywell warrants goods of its manufacture as being free of defective materials and faulty workmanship during the applicable warranty period. Honeywell's standard product warranty applies unless agreed to otherwise by Honeywell in writing; please refer to your order acknowledgment or consult your local sales office for specific warranty details. If warranted goods are returned to Honeywell during the period of coverage, Honeywell will repair or replace, at its option, without charge those items that Honeywell, in its sole discretion, finds defective. **The foregoing is buyer's sole remedy and is in lieu of all other warranties, expressed or implied, including those of merchantability and fitness for a particular purpose. In no event shall Honeywell be liable for consequential, special, or indirect damages.**

While Honeywell may provide application assistance personally, through our literature and the Honeywell web site, it is buyer's sole responsibility to determine the suitability of the product in the application.

Specifications may change without notice. The information we supply is believed to be accurate and reliable as of this writing. However, Honeywell assumes no responsibility for its use.

## ⚠ WARNING MISUSE OF DOCUMENTATION

- The information presented in this product sheet is for reference only. Do not use this document as a product installation guide.
- Complete installation, operation, and maintenance information is provided in the instructions supplied with each product.

**Failure to comply with these instructions could result in death or serious injury.**

## SAFETY NOTE

This sensor is designed to be used in safety-critical applications. To ensure that the sensor and/or instrument in which it is used, are operating properly, it is a requirement that the function of the device is confirmed by exposure to target gas (bump check) before each use of the sensor and/or instrument. Failure to carry out such tests may jeopardize the safety of people and property.

Under no circumstances should intelligent sensor pads be soldered to, as this can cause problems. Connection should be made via a mounting socket and spring connector.

**WARNING: SOLDERING TO PADS WILL RENDER YOUR WARRANTY VOID.**



株式会社 **クローネ**

■カタログに掲載してある製品の色は印刷インキの関係上、実際とは異なる場合があります。  
■製品のデザイン、仕様等などは、予告なく変更する場合があります。

本 社：〒124-0023 東京都葛飾区東新小岩3丁目9番6号 TEL: (03) 3695-5431 / FAX: (03) 3695-5698  
大阪支店：〒530-0054 大阪市北区南森町2-2-9(南森町八千代ビル7F) TEL: (06) 6361-4831 / FAX: (06) 6361-9360  
e-mail: sales-tokyo@krone.co.jp URL: <https://www.krone.co.jp>

**Honeywell**  
**Advanced Sensing Technologies**  
830 East Arapaho Road  
Richardson, TX 75081  
[sps.honeywell.com/ast](https://sps.honeywell.com/ast)

002707-3-EN | 3 | 11/21  
© 2021 Honeywell International Inc. All rights reserved.

**Honeywell**