



## TECHNICAL DATASHEET



The TCM CLASSIC product line meets general industrial requirements out of the box.

- TCE 8000 transmitters with an easy-to-use interface
- Economically-priced, non-calibrated but with excellent repeatability
- Optional custom-calibrated meters with high performance specifications



*Our passion is*  
**your *Process***



# CONTENT

Description, Principle of operation .....	04
Product Overview .....	05
TCM Sensor – Technical Data for Liquids .....	06
Accuracy for Liquids .....	07
TCM Sensor – Technical Data for Gases .....	08
Accuracy for Gases .....	09
TCE 8000/8100 Transmitter – Technical Data .....	10
TCE 6000 Transmitter – Technical Data .....	11
TRD 8001 Remote Display - Technical Data .....	11
Dimensional Drawings .....	12
Ordering Code TCM Meter (TRICOR CLASSIC Series) .....	19
Ordering Code TCE Transmitter (Series 8XXX) .....	20
Cable Specifications, Accessories .....	21
Process Connections .....	22
Contact .....	28



## DESCRIPTION

The TRICOR Coriolis Mass Flow Meters from TASI Flow are absolutely reliable and robust sensors in a variety of processes, performing multiple measurements simultaneously with customizable process parameters and multiple communication languages. The TRICOR production team mechanically balances every meter, assuring the dual tubes are dynamically aligned and in perfect balance before flow begins. The unique design and cutting edge manufacturing procedures ensure a meter with the highest resistance to external influences.

## FEATURES

- All-in-one instrument: direct measurement of mass flow, density and temperature, calculated measurement of volumetric flow
- No moving parts: low maintenance, no need for recalibration
- Easy to install: no straight run of pipe required and multiple mounting options available
- Mechanically balanced tubes and superior mechanical design for best-in-class density measurement
- Exceptional mechanical design resists external interference
- API gravity reading in software
- Exceptional ease of use and fast setup time: we will pre-program your process parameters
- Frequency output up to 10,000 Hz resolution
- Superior meter calibration: DAkkS-Accreditation as per DIN EN ISO/IEC 17025:2018
- Easily accessible, integrated meter diagnostics to verify meter health & performance
- Hazardous area certifications: ATEX, IECEx, cCSAus, EAC (TR-CU)
- Customized process connections available

## ADDITIONAL OPTIONS

- Net Oil software
- High pressure designs available up to 345 bar [5,000 psi]
- Special calibrations for an oil viscosity up to 100 mm<sup>2</sup>/s
- Integrated pressure compensation
- Customizable installation length
- Extended warranty

## PRINCIPLE OF OPERATION

Coriolis Mass Flow Meters (TCM) operate with two parallel tubes with coils that cause them to oscillate at their resonance frequency. Should a measurement flow enter the measuring tube, Coriolis forces are the result. Coriolis forces appear in oscillating systems when a mass moves towards or away from a rotational axis. These forces act on the inlet and outlet side in the opposite direction and minimally deform the measuring tubes. The deflection of the measurement tubes is captured by sensors on the inflow and outflow side. These two sensors measure a phase shift that is proportional to the mass flow. The resonance frequency of the tubes varies depending on the density of the medium to be measured. This effect is used to measure the density of the medium. Since the elastic properties of the flow tubes depend on the temperature, a temperature measurement is carried out for compensation. The primary characteristics such as mass flow rate, density and temperature are measured with a single flow meter. The volume flow can be determined based on the mass flow rate and density.

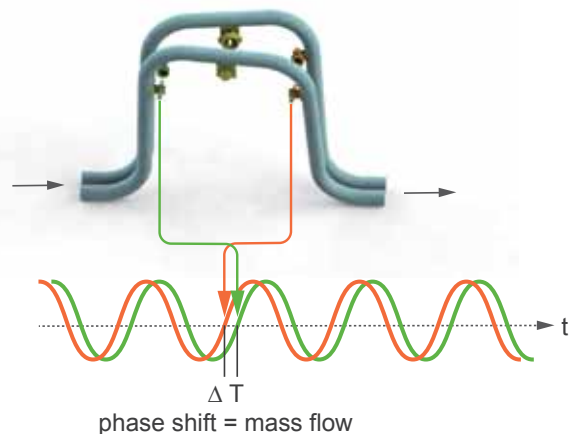



PRODUCT OVERVIEW

Compact version



Exd housing: Wall mounted (remote version)



Version with TCE 6000 (including options)



Housing: Panel mounted (remote version)





## TCM SENSOR – TECHNICAL DATA FOR LIQUIDS

	TCM 0325	TCM 0650	TCM 1550	TCM 3100	TCM 5500	TCM 7900	TCM 028K	TCM 065K	TCM 230K
Max. Flow Rate (kg/h)	325	650	1,550	3,100	5,500	7,900	28,000	65,000	230,000
Max. Flow Rate (lb/min)	12	24	57	114	202	290	1,029	2,388	8,450
Basic Accuracy (Mass Flow)	±0.3 % of flow rate (option: up to 0.1 % of flow rate)								±0.3 % (option: ±0.15 %)
Basic Accuracy (Volume Flow)	±0.3 % of flow rate (option: up to 0.15 % of flow rate)								±0.3 % (option: ±0.2 %)
Repeatability	±0.05 % of flow rate								
Zero Stability	±0.01 % of full scale								±0,015 %
Density Range	up to 2,500 kg/m <sup>3</sup> [2.5 g/cm <sup>3</sup> ] (higher ranges on request)								
Density Accuracy	±1.0 kg/m <sup>3</sup> [±0.001 g/cm <sup>3</sup> ]								
Density Repeatability	±0.5 kg/m <sup>3</sup> [±0.0005 g/cm <sup>3</sup> ]								
Process Temperature Range	±1 °C ±0.5 % of reading [±1.8 °F ±0.5 % of reading]								
Temperature Repeatability	±0.2 °C [±0.36 °F]								

Process and Ambient										
Process Connections	female thread ½“ adaptors for flanges, dairy and tri-clamp				flanges EN1092, ANSI B16.5, DIN2512, threaded tri-clamp					
Max. Pressure Standard	200 bar [2,900 psi] option: up to 345 bar [5,000 psi] (not for ASME)					100 bar [1,450 psi]				
Pressure Drop at max. Flow	for detail information please contact us									
Process Temperature (non Ex)	-40 °C ... +100 °C [-40 °F ... +212 °F] (standard) -40 °C ... +150 °C [-40 °F ... +302 °F] (option) -60 °C ... +200 °C [-76 °F ... +392 °F] (option)									
Process Temperature (Ex)	meter mount	-40 °C ... +70 °C [-40 °F ... +158 °F] (T4)							n/a	
	remote version	-40 °C ... +70 °C [-40 °F ... +158 °F] (T4) -40 °C ... +135 °C [-40 °F ... +275 °F] (T3) -60 °C ... +200 °C [-76 °F ... +392 °F] (T2)								
Ambient Temperature	-40 °C ... +70 °C [-40 °F ... +158 °F]									
Storage Temperature	-40 °C ... +100 °C [-40 °F ... +212 °F]									
Electr. Connections Remote	screw type terminals									
Electr. Connections Meter Mount	none (internally connected to the electronics)									
Ingress Protection	IP65 (IP66/IP67 on request)									

General									
Tube Arrangement	2 serial	2 parallel	2 serial	2 parallel	2 parallel	2 parallel	2 parallel	2 parallel	2 parallel
Tube Inner Diameter	4 mm	4 mm	8 mm	8 mm	7 mm	9 mm	16 mm	28 mm	43 mm
Tube Material	1.4404 [AISI 316L]								
Housing Material	1.4404 [AISI 316L]								
Dimensions	see dimensional drawings (page 12 - 13)								

*Calibration for Liquids and Gases: The TRICOR flowmeters are always factory calibrated with water.  
Calibration Conditions: Water: 20 °C ... 25 °C [68 °F ... 77 °F], ambient temperature: 20 °C ... 25 °C [68 °F ... 77 °F].  
All specifications are based on above mentioned calibration reference conditions, a flow calibration protocol is attached to each instrument.  
Stated accuracy combines the effects of repeatability, linearity and hysteresis.  
Typical flow dynamics based on max. flow rate is 100:1.*



ACCURACY FOR LIQUIDS (TCM 0325 TO TCM 065K)

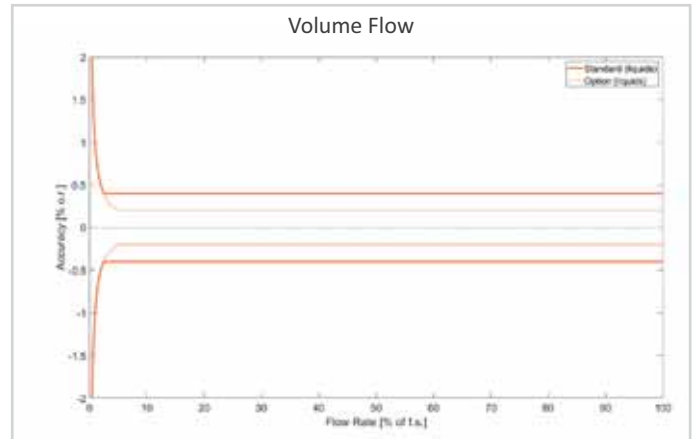
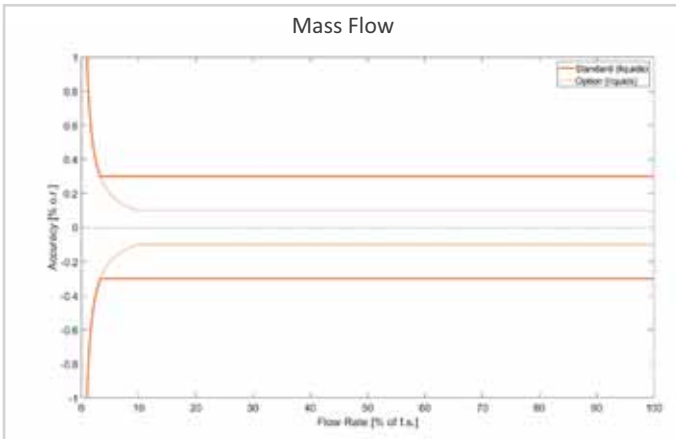

ACCURACY FOR LIQUIDS (TCM 230K)

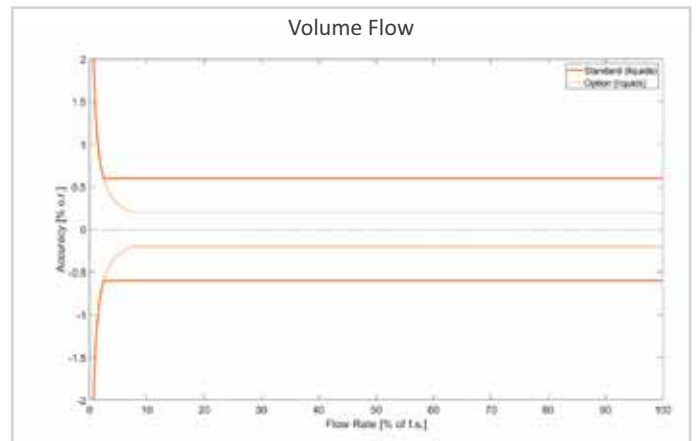
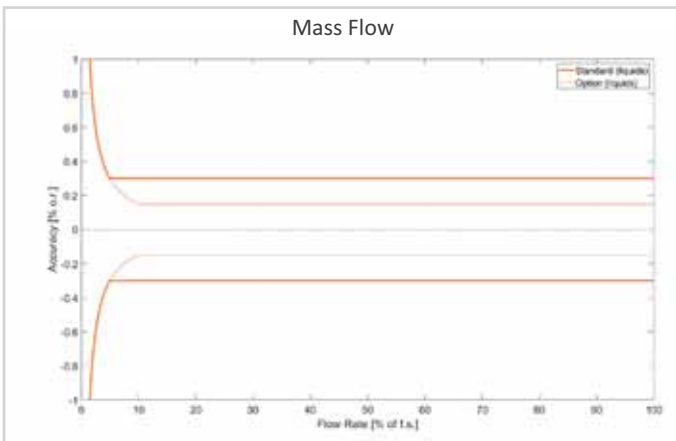

Flow Rate of Full Scale	Accuracy
$\geq \frac{\text{Zero Point}}{\text{Basic Accuracy}} * 100$	$\pm \text{Basic Accuracy}$
$< \frac{\text{Zero Point}}{\text{Basic Accuracy}} * 100$	$\pm \frac{\text{Zero Point}}{\text{Measured Value}} * 100$



## TCM SENSOR – TECHNICAL DATA FOR GASES

	TCM 0325	TCM 0650	TCM 1550	TCM 3100	TCM 5500	TCM 7900	TCM 028K	TCM 065K	TCM 230K	
Nom. Flow Rate (kg/h) <sup>1) 3)</sup>	78	177	333	740	910	1,430	5,100	15,650	48,900	
Nom. Flow Rate (lb/min) <sup>1) 3)</sup>	3	7	12	27	34	53	188	575	1,797	
Nom. Flow Rate (Nm <sup>3</sup> /h) <sup>1) 2)</sup>	109	247	464	1,031	1,268	1,993	7,109	21,813	68,157	
Nom. Flow Rate (SCFM) <sup>1) 2)</sup>	64	146	273	607	747	1,173	4,184	12,838	40,115	
Basic Accuracy	±1 % of flow rate (option: up to ±0.5 % of flow rate)									
Repeatability	±0,25 % of flow rate									
Zero Stability (kg/h)	0.0325	0.065	0.155	0.31	0.55	0.79	2.8	6.5	23	
Zero Stability (lb/min)	0.0012	0.0024	0.0057	0.0114	0.020	0.029	0.103	0.239	0.845	
Density Range	see comment <sup>3)</sup>									
Density Accuracy	±1.0 kg/m <sup>3</sup> [±0.001 g/cm <sup>3</sup> ]									
Density Repeatability	±0.5 kg/m <sup>3</sup> [±0.0005 g/cm <sup>3</sup> ]									
Process Temperature Range	±1 °C ±0.5 % of reading [±1.8 °F ±0.5 % of reading]									
Temperature Repeatability	±0.2 °C [±0.36 °F]									
<b>Prozess-/Umgebungsbedingungen</b>										
Process Connections	female thread ½“ adaptors for flanges, dairy and tri-clamp				flanges EN1092, ANSI B16.5, DIN2512, threaded tri-clamp					
Max. Pressure Standard	200 bar [2,900 psi] option: up to 345 bar [5,000 psi] (not for ASME)					100 bar [1,450 psi]				
Pressure Drop at max. Flow	for detail information please contact us									
Process Temperature (non Ex)	-40 °C ... +100 °C [-40 °F ... +212 °F] (standard) -40 °C ... +150 °C [-40 °F ... +302 °F] (option) -60 °C ... +200 °C [-76 °F ... +392 °F] (option)									
Process Temperature (Ex)	meter mount	-40 °C ... +70 °C [-40 °F ... +158 °F] (T4)							n/a	
	remote version	-40 °C ... +70 °C [-40 °F ... +158 °F] (T4) -40 °C ... +135 °C [-40 °F ... +275 °F] (T3) -60 °C ... +200 °C [-76 °F ... +392 °F] (T2)								
Ambient Temperature	-40 °C ... +70 °C [-40 °F ... +158 °F]									
Storage Temperature	-40 °C ... +100 °C [-40 °F ... +212 °F]									
Electr. Connections Remote	screw type terminals									
Electr. Connections Meter Mount	none (internally connected to the electronics)									
Ingress Protection	IP65 (IP66/IP67 on request)									
<b>General</b>										
Tube Arrangement	2 serial	2 parallel	2 serial	2 parallel	2 parallel	2 parallel	2 parallel	2 parallel	2 parallel	
Tube Inner Diameter	4 mm	4 mm	8 mm	8 mm	7 mm	9 mm	16 mm	28 mm	43 mm	
Tube Material	1.4404 [AISI 316L]									
Housing Material	1.4404 [AISI 316L]									
Dimensions	see dimensional drawings (page 12 - 13)									

Max. allowed flow velocity (Ma 0.5).

For gas applications, flow rate and pressure drop for individual sensor sizes are dependent on operating temperature, pressure and fluid composition. Therefore, when selecting a sensor for any particular gas application, please use the TSP (TRICOR Sizing Program) or contact us.

<sup>1)</sup> Nominal flow rates that produce approximately 3 bar [43 psi] pressure drop for natural gas at 50 bar [725 psi] operational pressure.

<sup>2)</sup> Normal reference conditions (Nm<sup>3</sup>/h) are 1,013 bar und 0 °C. Standard (SCFM) reference conditions are 14.7 psi und 60 °F.

<sup>3)</sup> Flow rate and density range depend on the gas density and the pressure range.





ACCURACY FOR GASES

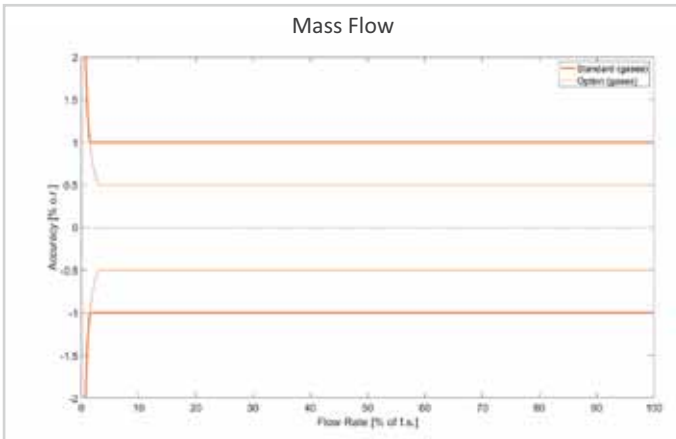

Flow Rate of Full Scale	Accuracy
$\geq \frac{\text{Zero Point}}{\text{Basic Accuracy}} * 100$	$\pm \text{Basic Accuracy}$
$< \frac{\text{Zero Point}}{\text{Basic Accuracy}} * 100$	$\pm \frac{\text{Zero Point}}{\text{Measured Value}} * 100$

APPROVALS & CERTIFICATIONS

	TCM 0325, 0650, 1550, 3100, 5500 and 7900	TCM 028K, 065K and 230K
<b>ATEX Zone 1</b>	Compact version: II 2G Ex db ia IIC T4 Gb Remote version <sup>5)</sup> : Sensor: II 1G Ex ia IIC T4...T2 Ga Transm.: II 2(1)G Ex db [ia Ga] IIC T4 Gb	Compact version: II 2G Ex db ia IIB T4 Gb Remote version <sup>5)</sup> : Sensor: II 1G Ex ia IIB T4...T2 Ga Transm.: II 2(1)G Ex db [ia Ga] IIB T4 Gb
<b>ATEX Zone 2</b>	All versions: II 3G Ex nA IIC T4	All versions: II 3G Ex nA IIC T4
<b>IECEX</b>	Compact version: Ex db ia IIC T4 Gb Remote version <sup>5)</sup> : Sensor: Ex ia IIC T4...T2 Ga Transm.: Ex db [ia Ga] IIC T4 Gb	Compact version: Ex db ia IIB T4 Gb Remote version <sup>5)</sup> : Sensor: Ex ia IIB T4...T2 Ga Transm.: Ex db [ia Ga] IIB T4 Gb
<b>cCSAus<sup>4)</sup></b>	Compact version: Cl. 1, Div. 1, Group A-D: T4 (US, Can) Ex db ia IIC T4 Gb (Can) Remote version <sup>5)</sup> : Sensor: Cl. 1, Div. 1, Group A-D: T4...T2 (US, Can) Ex ia IIC T4...T2 Ga (Can) Transm.: Cl. 1, Div. 1, Group A-D: T4 (US, Can) Ex db [ia Ga] IIC T4 Gb (Can)	Compact version: Cl. 1, Div. 1, Group C, D: T4 (US, Can) Ex db ia IIB T4 Gb (Can) Remote version <sup>5)</sup> : Sensor: Cl. 1, Div. 1, Group C, D: T4...T2 (US, Can) Ex ia IIB T4...T2 Ga (Can) Transm.: Cl. 1, Div. 1, Group C, D: T4 (US, Can) Ex db [ia Ga] IIB T4 Gb (Can)
<b>EAC (TR-CU)</b>	Compact version: 1Ex d [ia] IIC T4 Remote version <sup>5)</sup> : Sensor: 1Ex ia IIC T4...T2 X Transm.: 1Ex d [ia] IIC T4	Compact version: 1Ex d [ia] IIB T4 Remote version <sup>5)</sup> : Sensor: 1Ex ia IIB T4...T2 X Transm.: 1Ex d [ia] IIB T4
<b>KGS (Korean)</b>	Compact version: Ex d [ia] IIC T4 Remote version <sup>5)</sup> : Sensor: Ex ia IIC T4 Transm.: Ex d [ia] IIC T4	Compact version: Ex d [ia] IIB T4 Remote version <sup>5)</sup> : Sensor: Ex ia IIB T4 Transm.: Ex d [ia] IIB T4

<sup>4)</sup> For cCSAus the electronic is only available in aluminum housing.

<sup>5)</sup> Only wall mounting, not panel mounting.



## TCE 8000/8100 TRANSMITTER – TECHNICAL DATA

General	
Supply Voltage	24 V DC or 100 ... 240 V AC (version dependent)
Power Consumption	max. 4 W (DC version) max. 11 W (AC version)
Environmental Conditions	<ul style="list-style-type: none"> <li>• Transient over voltages up to the levels of overvoltage category II</li> <li>• Temporary over voltages occurring on mains supply only</li> <li>• POLLUTION DEGREE 2</li> <li>• MAINS AC supply voltage fluctuations up to <math>\pm 10\%</math> of the nominal voltage</li> <li>• Altitude up to 2.000 m</li> </ul>
Reverse Polarity Protection	yes
Galvanic Isolation	2,500 V AC
Display	back-lit LCD screen, 132 x 32 dot
Programming	via front keyboard or Windows-based TRICOR configurator program (Modbus)
Interfaces	RS485 (Modbus-RTU), option HART®, Foundation Fieldbus®, other options on request
Cable Glands	Suitable for $\varnothing$ 7 - 13 mm cables Material: Brass/Ni plated (option: 1.4404 [AISI 316]) Thread: 2 x ½" NPT or 2 x M20 x 1.5
<i>ExD Housing: Wall-mounted</i>	
Dimensions	see dimensional drawing (page 14 - 15)
Electrical Connections	cage clamp terminals
Sensor Cable Glands	barrier cable gland: applied by manufacturer (thread: ½" NPT)
Housing Material	aluminum diecast (option: 1.4404 [AISI 316L])
Protection Class	IP65 (IP66/IP67 on request)
Weight	with aluminum diecast housing: 3.8 kg [8.3 lb] with 3 m cable with 1.4404 [AISI 316L] housing: 6.15 kg [13.56 lb]
Temperature	ambient: -40 °C ... +70 °C [-40 °F ... +158 °F] storage and transport: -40 °C ... +80 °C [-40 °F ... +176 °F]
<i>Housing: Panel-mounted (only TCE 8000)</i>	
Dimensions	see dimensional drawing (page 17)
Electrical Connections	cage clamp terminals
Housing Material	Noryl
Protection Class	front: IP50, rear: IP30
Weight	0.4 kg [0.88 lb]
Temperature	ambient: $\pm 0$ °C ... +60 °C [32 °F ... +140 °F] storage and transport: -20 °C ... +70 °C [-4 °F ... +158 °F]
Analog Output	
Current Outputs (2x)	4 ... 20 mA passive, two-wire, isolated
Resolution	14 bit
Linearity	$\pm 0.05\%$ of full scale
Temperature Drift	0.05 % per 10 K
Load	< 620 $\Omega$ (at 24 V supply)
Output Value	programmable: flow, total, density, temperature
Pulse Output	
Frequency Range	0.5 - 10,000 Hz (in TOTAL mode: 0 - 100 Hz)
Output Signal	active push pull output for flow rate
Status In- and Output	
Status Output	push pull programmable (in FREQUENCY mode: 0.5 - 10,000 Hz)
Control Input	programmable
Analog Input (option)	
Input Type	4 ... 20 mA active for two-wire passive pressure sensor
Resolution	12 bit
Linearity	$\pm 0.05\%$ of full scale
Temperature Drift	0.05 % per 10 K
Supply Voltage	> 20 V (at 20 mA sensor current)



## TCE 6000 TRANSMITTER – TECHNICAL DATA

General	
Supply Voltage	24 V DC
Programming	via TRD 8001 or via interface
Interfaces	RS485, USB (option)
EMC	according to EN 61000-6-4 and EN 61000-6-2
Power Consumption	max. 4 W
Dimensions	see dimensional drawing (page 17)
Electrical Connections	connectors M12
Housing Material	aluminum diecast
Temperature	ambient: : -40 °C ... +70 °C [-40 °F ... +158 °F] storage and transport: -40 °C ... +80 °C [-40 °F ... +176 °F]
Protection Class	IP65
Analog Output	
Current Output	4 ... 20 mA active
Resolution	14 bit
Linearity	±0.05 %
Temperature Drift	0.05 % per 10 K
Load	< 800 Ω
Output Value	programmable: flow, total, density, temperature
Pulse Output	
Frequency Range	0.5 - 10,000 Hz (for ESTA (OPTV receiver) 0.5 - 5,000 Hz)
Output Signal	active push pull output for flow rate, optional: insulated optical frequency output
Status In- and Output	
Status Output	push pull programmable (option) (in TOTAL mode: 0.5 - 100 Hz)
Control Input	programmable (standard: 1 input/option: 2 inputs) option: insulated optical control input

Note: For parameterization of the flow meter, the interface may be used.  
Prerequisite: Parameter setting is not allowed during active ESTA operation.

## TRD 8001 REMOTE DISPLAY – TECHNICAL DATA

Display	back-lit LCD screen, 132 x 32 dot
Supply Voltage	via interface
Programming	via front keyboard
Interface to TCE	RS485
EMC	according to EN 61000-6-4 and 61000-6-2
Dimensions	see dimensional drawing (page 18)
Electrical Connections	connectors M12
Housing Material	ABS-FR (plastic, flame retardant)
Protection Class	IP64
Weight	0.4 kg [0.88 lb]
Temperature	operation: ±0 °C ... +60 °C [32 °F ... +140 °F] storage and transport: -20 °C ... +80 °C [-4 °F ... +176 °F]
Wall Mount	hidden screws



## SENSORES TCM 0325 TO TCM 0650

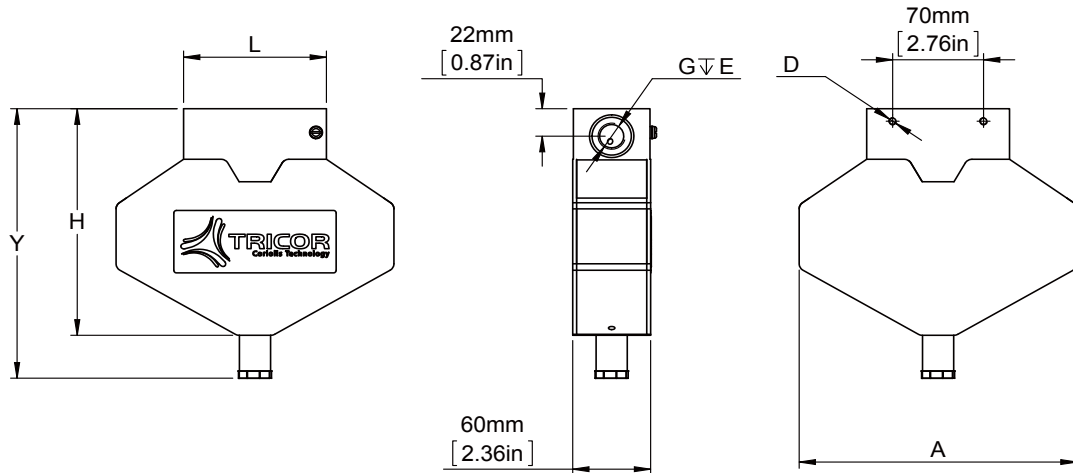

Sensor Type	A	D	E	G <sup>6)</sup>	H	L <sup>7)</sup>	Y
TCM 0325	214 mm [8.43 in]	M6 ∇ 10	15 mm [0.59 in]	G ½"	182 mm [7.17 in]	110 mm [4.33 in]	216 mm [8.50 in]
TCM 0650	214 mm [8.43 in]	M6 ∇ 10	15 mm [0.59 in]	G ½"	182 mm [7.17 in]	110 mm [4.33 in]	216 mm [8.50 in]

## SENSORS TCM 1550 TO TCM 3100

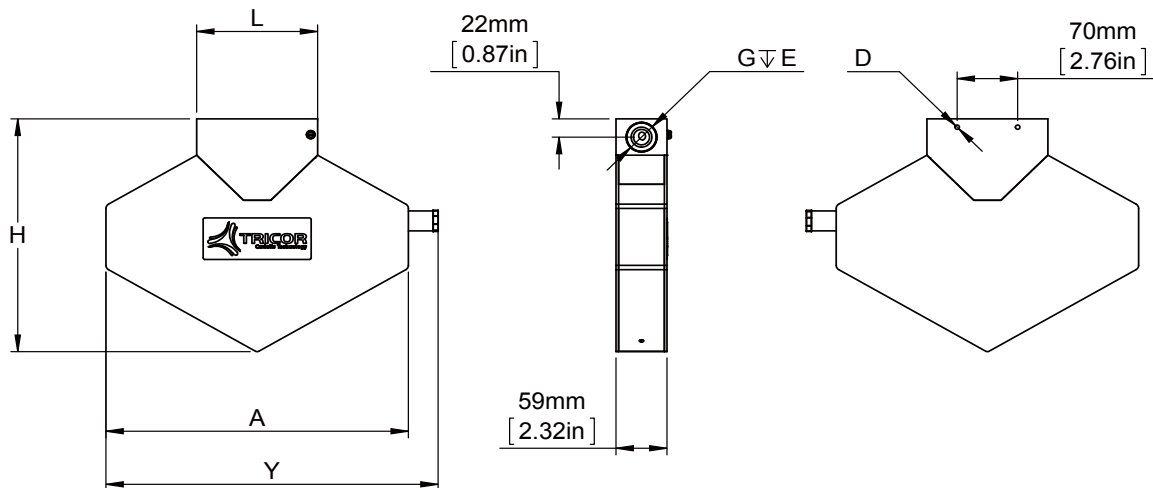

Sensor Type	A	D	E	G <sup>6)</sup>	H	L <sup>7)</sup>	Y
TCM 1550	350 mm [13.78 in]	M6 ∇ 10	18 mm [0.71 in]	G ½"	280 mm [11.02 in]	140 mm [5.51 in]	384 mm [15.12 in]
TCM 3100	350 mm [13.78 in]	M6 ∇ 10	18 mm [0.71 in]	G ½"	280 mm [11.02 in]	140 mm [5.51 in]	384 mm [15.12 in]

<sup>6)</sup> Other connections on request.

<sup>7)</sup> Further lengths on request.



## SENSORS TCM 5500 TO TCM 065K

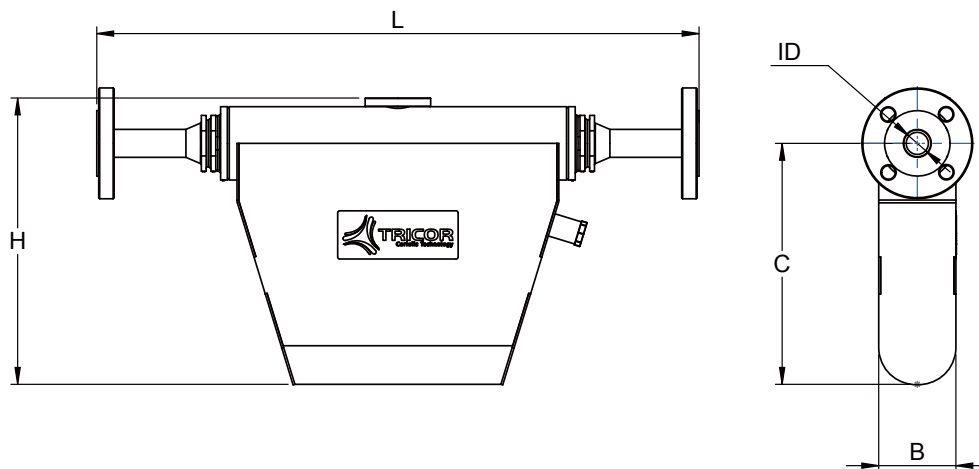

Sensor Type	B	C	H	L <sup>8)</sup>	I.D.	Connection
TCM 5500, 7900	61 mm [2.40 in]	204 mm [8.03 in]	260 mm [10.24 in]	460 mm [18.11 in]	∅ 13 mm [∅ 0.51 in]	on request
TCM 028K	80 mm [3.15 in]	253 mm [9.96 in]	315 mm [12.40 in]	625 mm [24.61 in]	∅ 23 mm [∅ 0.91 in]	on request
TCM 065K	151 mm [5.94 in]	387 mm [15.24 in]	480 mm [18.90 in]	830 mm [32.68 in]	∅ 40 mm [∅ 1.57 in]	on request

## SENSOR TCM 230K

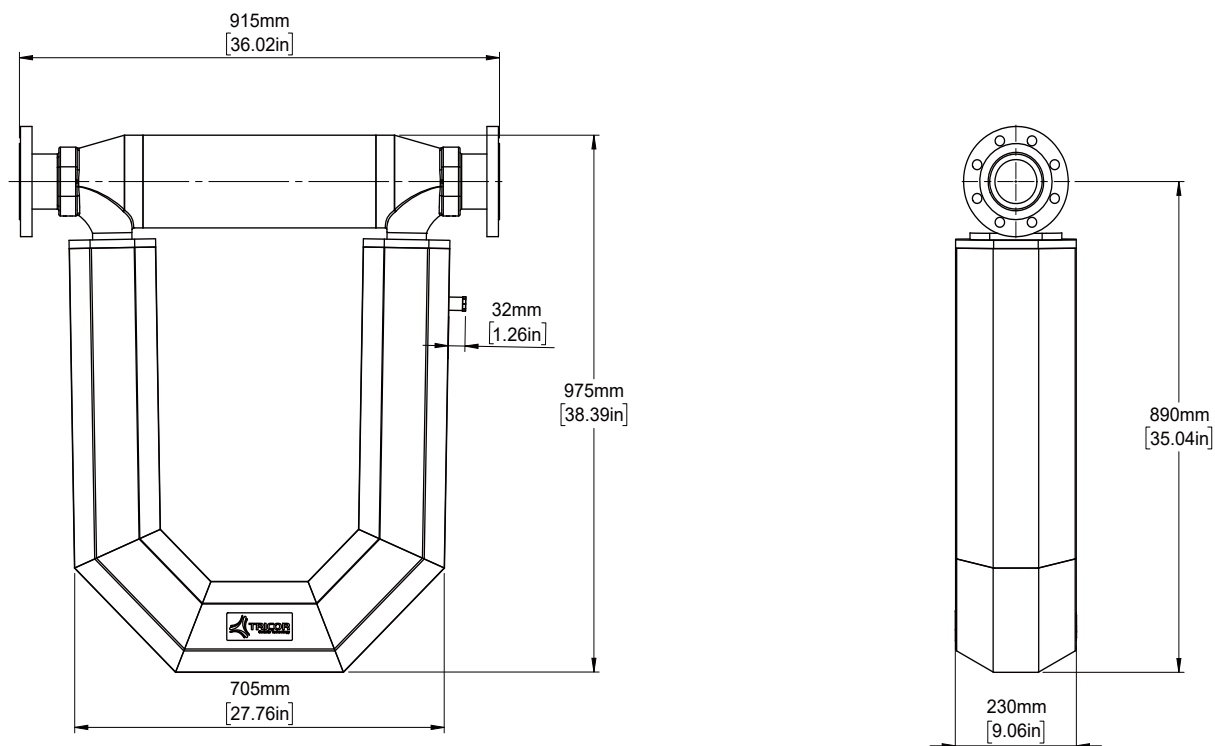

<sup>8)</sup> Further lengths on request.



## WALL-MOUNT TRANSMITTER TCE 8000/8100 (NOT FOR HAZARDOUS AREA)

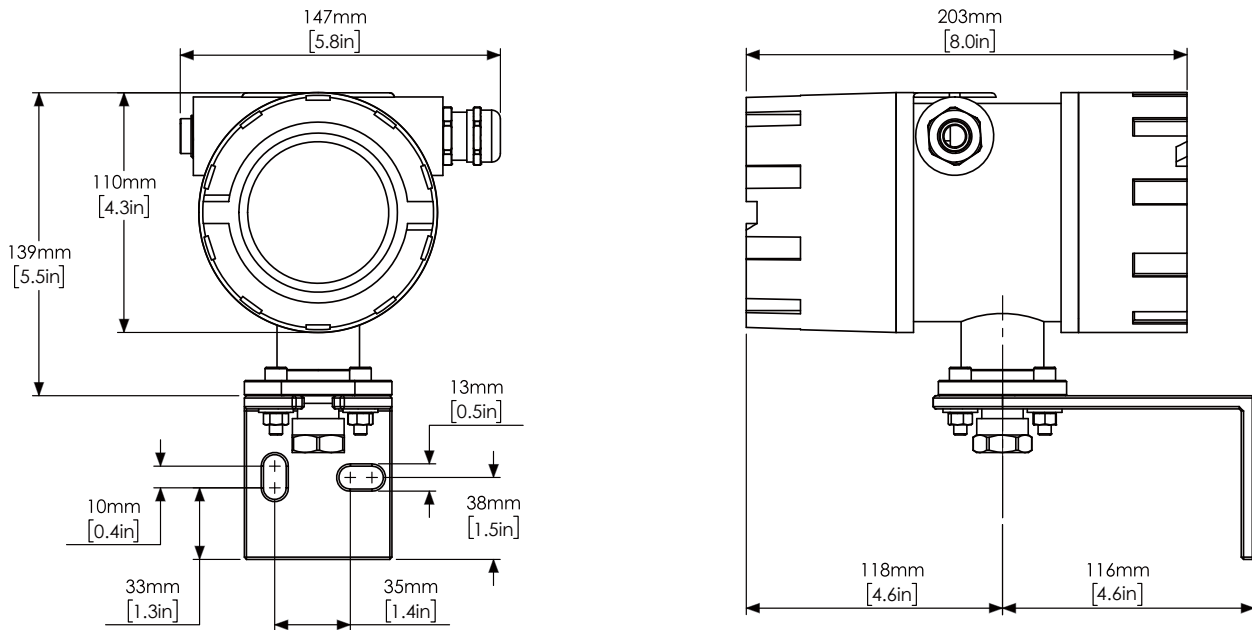

## WALL-MOUNT TRANSMITTER TCE 8000/8100 (FOR HAZARDOUS AREA)

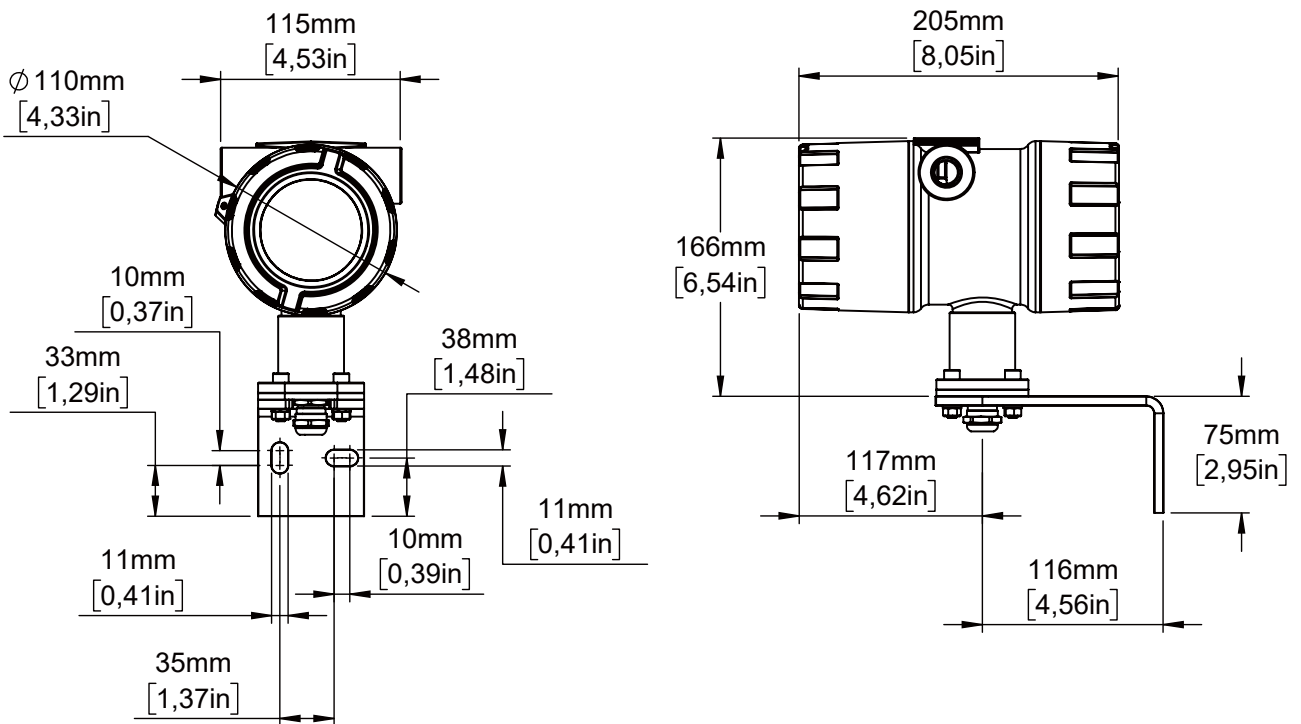



METER-MOUNT TRANSMITTER TCE 8000/8100

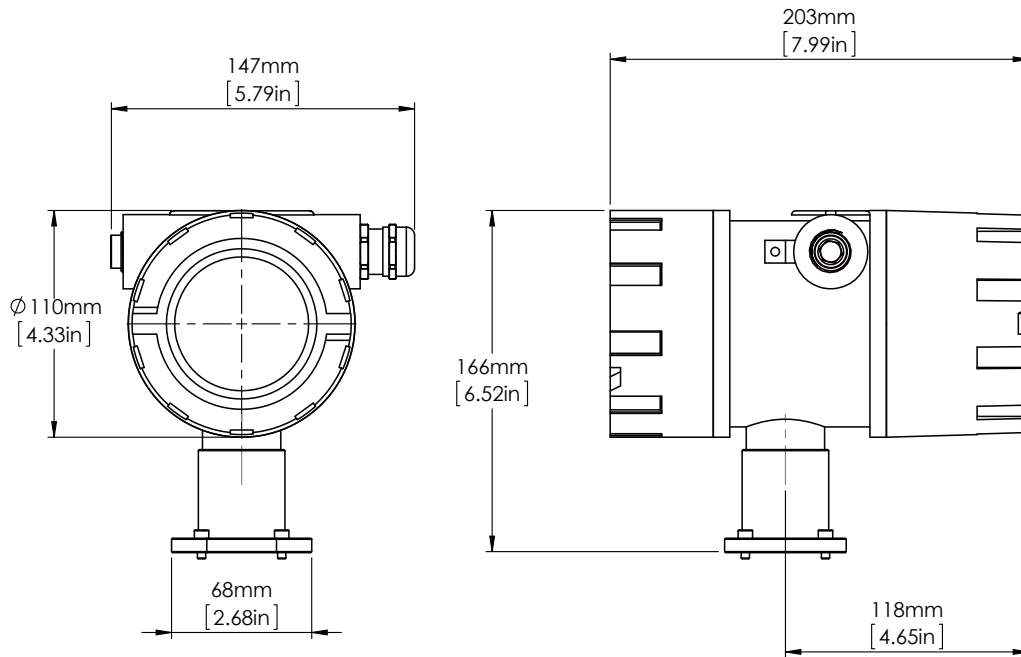

METER-MOUNT TRANSMITTER TCE 8000/8100 WITH BLIND COVER

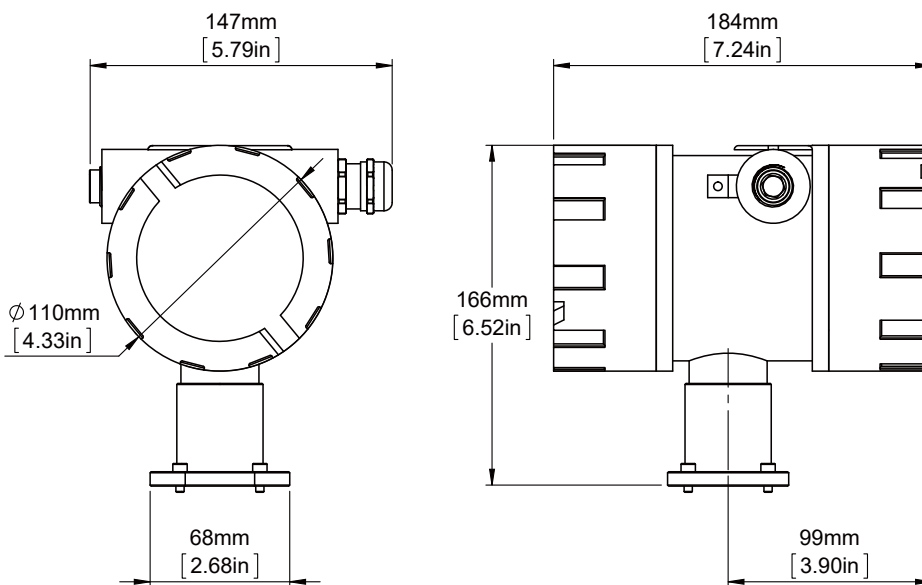



## METER-MOUNT TRANSMITTER TCE 8000/8100 HIGH TEMPERATURE (NOT FOR HAZARDOUS AREAS)

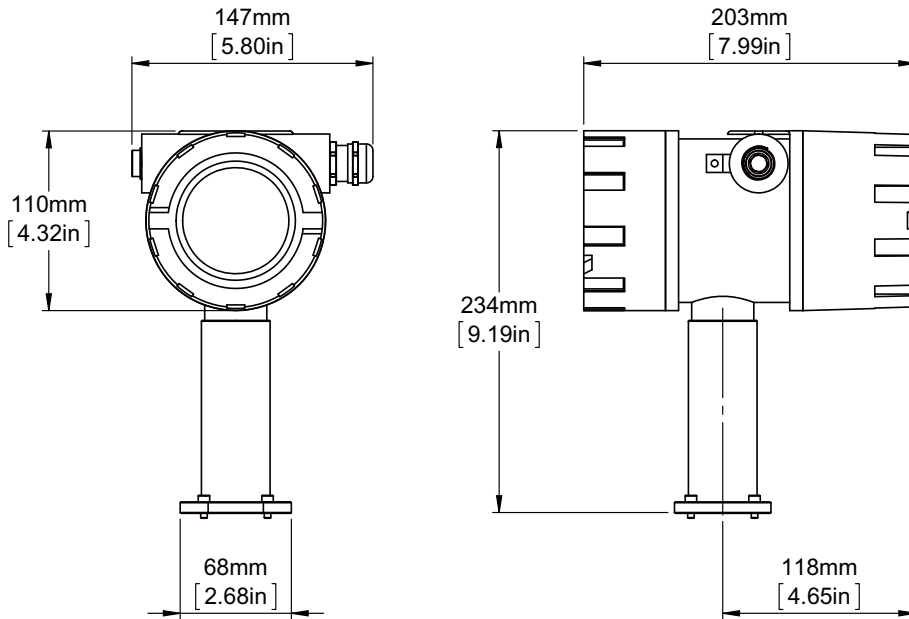

## STANDARD CONNECTION HEAD (A)

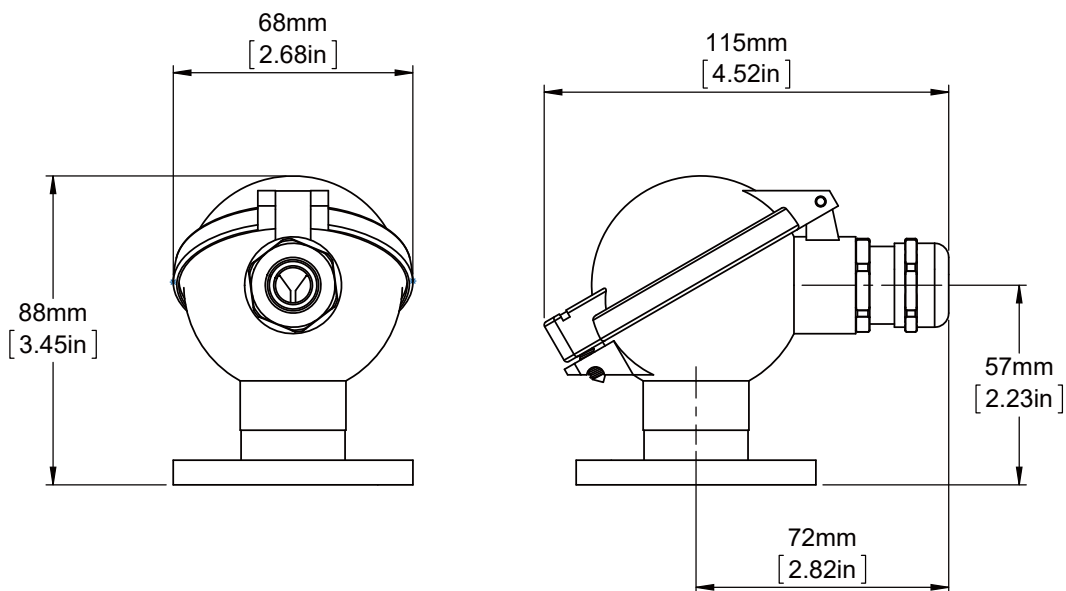





HIGH TEMPERATURE CONNECTION HEAD (H)

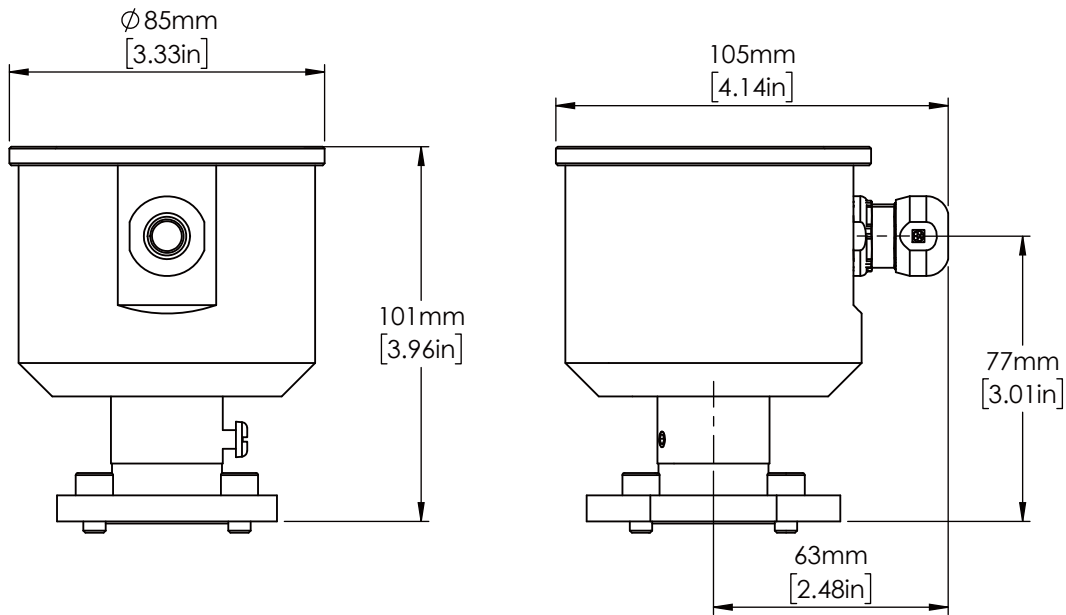

PANEL-MOUNTED HOUSING

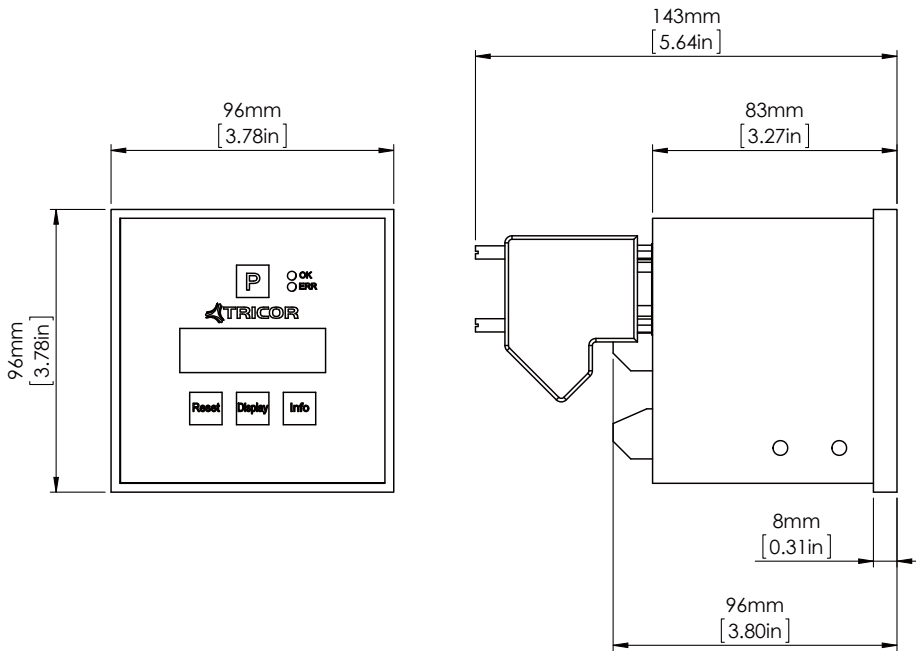



## METER-MOUNT TRANSMITTER TCE 6000 (F)

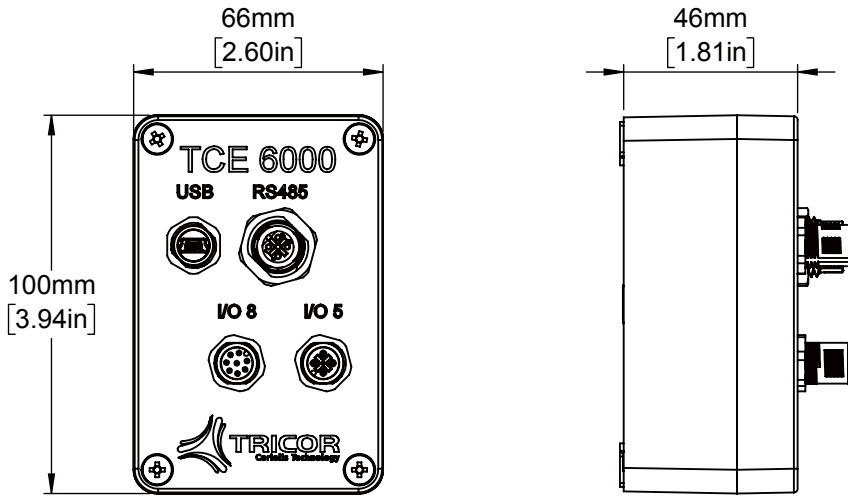

## REMOTE DISPLAY TRD 8001

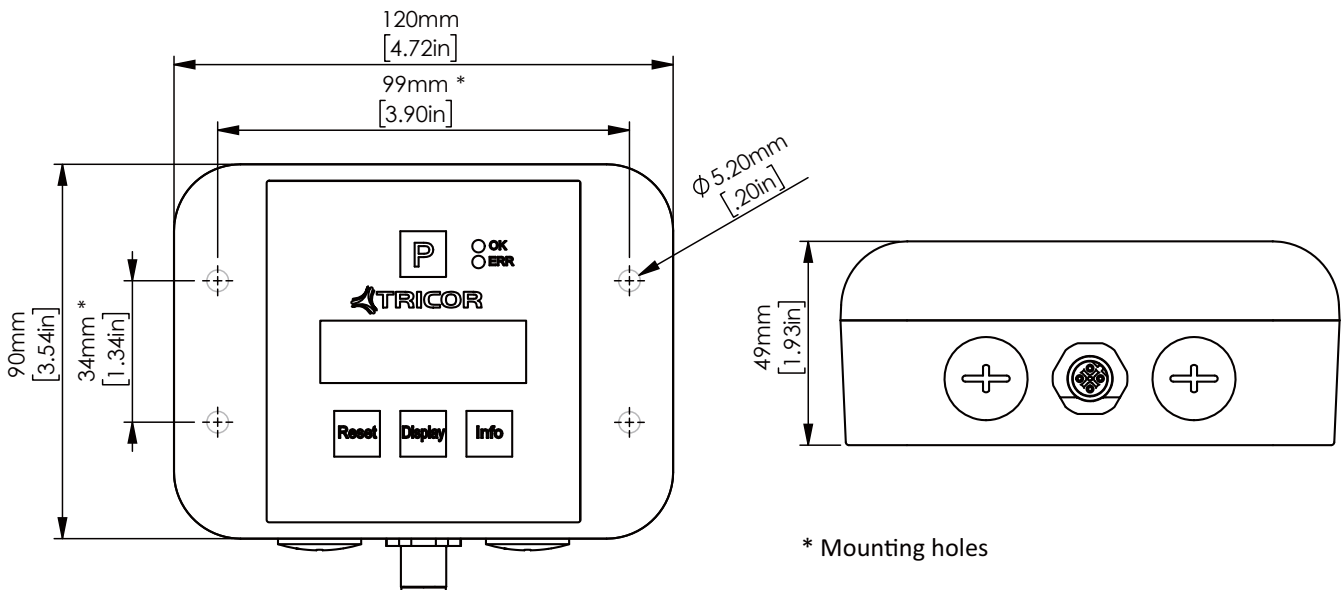



ORDERING CODE TCM SENSOR (TRICOR CLASSIC SERIES)

	TCM	XXXX	-	XX	-	X	X	X	X	-	X	X	X	X	-	Ex	-	XX
<b>Process Connections<sup>9)</sup></b>																		
see page 17 ff				XX														
<b>Mechanical Options</b>																		
<b>Medium Temperature Range</b>																		
-40 °C ... +100 °C [-40 °F ... +212 °F]																		
-40 °C ... +150 °C [-40 °F ... +302 °F], Ex <sub>max</sub> : 135 °C [275 °F]																		
-40 °C ... +70 °C [-40 °F ... +158 °F], Ex, compact																		
-60 °C ... +200 °C [-76 °F ... +392 °F]																		
<b>Pressure Range</b>																		
With rupture disc max. 4 bar [58 psi]																		
<b>Mechanical Design</b>																		
Standard																		
<b>Face to Face Length</b>																		
Standard (other length on request)																		
<b>Electronics Options</b>																		
<b>Electronics Type</b>																		
Junction box, 1.4404 [316L]																		
Meter mount, die cast aluminum housing for ½" NPT cable glands <sup>10)</sup>																		
Meter mount, die cast aluminum housing for M20x1.5 cable glands <sup>10)</sup>																		
Meter mount, stainless steel housing for ½" NPT cable glands <sup>10)</sup>																		
Meter mount, stainless steel housing for M20x1.5 cable glands <sup>10)</sup>																		
Meter mount electronics TCE 6000 <sup>11)</sup>																		
<b>Interface<sup>12)</sup></b>																		
RS485 (Modbus RTU)																		
RS485 (Modbus RTU) and HART®																		
RS485 (Modbus RTU) + FF (not with Ex)																		
FF (Foundation Fieldbus®)																		
RS485 (Modbus RTU) + USB (only TCE 6000)																		
Not used																		
<b>Supply Voltage</b>																		
24 V DC																		
90 ... 264 V AC																		
Not used																		
<b>Options</b>																		
Pressure compensation, 4 ... 20 mA input																		
8 pin I/O connector (TCE 6000 only)																		
Optical I/O (TCE 6000 only)																		
No option																		
<b>EX-Protection</b>																		
ATEX + IECEx (Zone 1)																		
ATEX (Zone 2)																		
cCSAus <sup>13)</sup>																		
cCSAus (TCE 6000)																		
ATEX + IECEx + cCSAus triple approval <sup>13) 14)</sup>																		
EAC (TR-CU)																		
KGS (Korea)																		
<b>Special Options</b>																		
NOC (Net Oil Computer)																		

<sup>9)</sup> For connections not indicated with installation length, please contact manufacturer.  
<sup>10)</sup> For TCM compact version with Ex-protection temperature class T4 only.  
<sup>11)</sup> Ex-protection only available in the option Exn. TCE 6000 electronic is not applicable for TCM 230K.  
<sup>12)</sup> Other interfaces on request.  
<sup>13)</sup> For Ex1 and Ex3 the electronic is only available in aluminum housing.  
<sup>14)</sup> Only with remote electronics.



## ORDERING CODE TCE TRANSMITTER (SERIES 8XXX)

	TCE	8	X	X	X	-	X	-	X	X	X	X	-	XX	-	XX
Housing material: Aluminum		8	0													
Housing material: stainless steel 1.4404 [AISI 316L]		8	1													
Electronics for TCM 0325 to TCM 7900				0	1											
Electronics for TCM 028K to TCM 065K				1	1											
Electronics for TCM 230K				1	2											
<b>Housing</b>																
Wall mount (housing for ½" NPT cable glands)																W
Wall mount (housing for M20x1.5 cable glands)																I
Panel mount <sup>15)</sup>																S
<b>Options</b>																
<b>Interface<sup>16)</sup></b>																
RS485 (Modbus RTU)																S
R485 (Modbus RTU) + HART <sup>®</sup>																A
<b>Supply Voltage</b>																
24 V DC + 90 ... 264 V AC (only housing S)																B
24 V DC																D
90 ... 264 V AC (only housing W, I)																M
<b>Electronic Options</b>																
Standard																S
Pressure compensation, 4 ... 20 mA input																A
<b>Cable Length</b>																
3 Meters [≈ 10 ft.], Standard (high temperature)																S (H)
6 Meters [≈ 20 ft.] (high temperature)																B (I)
10 Meters [≈ 33 ft.] (high temperature)																C (J)
15 Meters [≈ 49 ft.] (high temperature)																D (O)
20 Meters [≈ 65 ft.] (high temperature)																E (P)
3 Meters [≈ 10 ft.], offshore cable																F
D-SUB Connector (housing S), separate cable required																N
<b>Ex-Protection</b>																
ATEX + IECEx (Zone 1)																Ex
ATEX (Zone 2)																Exn
cCSAus <sup>17)</sup>																Ex1
cCSAus (TCE 6000)																Ex2
ATEX + IECEx + cCSAus triple approval <sup>17)</sup>																Ex3
EAC (TR-CU)																ExR
KGS (Korean)																ExK
<b>Special Options</b>																
NOC (Net Oil Computer)																

<sup>15)</sup> Only for TCE 80XX.

<sup>16)</sup> Other interfaces on request.

<sup>17)</sup> For Ex1 and Ex3 the electronic is only available in aluminum housing.



TRICOR CONNECTION CABLE (TCC) FOR PANEL-MOUNTED HOUSING

Cable Specifications/Connections

Cable	Connector TCE	Connector TCM	Devices	TCC		-	X X	
				X	X		X	X
Standard cable	SUB-D, 9-pin	cable end sleeves (8-pol.)	TCE 8**1-S-	0	2			
Standard cable	SUB-D, 9-pin/	cable end sleeves (8-pol.)	TCE 8**1-S-	0	4			
High temperature cable	SUB-D, 9-pin	cable end sleeves (8-pol.)	TCE 8**1-S-	0	9			
High temperature cable	SUB-D, 9-pin/	cable end sleeves (8-pol.)	TCE 8**1-S-	1	0			
<b>Length</b>								
3 meter (Standard)	[≈ 10 ft.]						0	3
6 meter	[≈ 20 ft.]						0	6
10 meter	[≈ 33 ft.]						1	0
15 meter	[≈ 49 ft.]						1	5
20 meter	[≈ 66 ft.]						2	0

ADDITIONAL ACCESSORIES

Accessories for TCE 8* electronic	Ordering Code
USB interface cable to RS485, 1.8 m (TRICOR configurator)	CON.USB.RS-ISO
IP65 Protection for TCE-80**-S	IPS 9-9
Adapter TCE-80**-S for rail mounting	HSA 96
Accessories for TCE 6000 electronic	Ordering Code
Remote display for TCE 6000	TRD 8001
Connection cable TRD 8001 to TCE 6000, 2 m	TRD-TCE-6-2
Connection cable TRD 8001 to TCE 6000, 5 m	TRD-TCE-6-5
USB Cable, USB to mini USB M12, 2 m	KAB-USB-TCE
RS485 to USB connector cable 3 m for TCE 6000; versions FSDS;FFDB, FSDC	KAB-RS485-TCE-ISO
Pneumatic Power Gen. Plug M8, 3 pin, 2.5 m cable for TCE 6000 Version FSDC; 7.5 W, 24 V DC	TCE 6000-FSDC-SET-PPG
Light pulse emitter and receiver, DIN-rail for TCE 6000 Version FSDC	OPTV-02/XO
Fiber optic cable for TCE 6000 Version FSDC for FOP 50/60, 10 m (5.5 mm)	LW-LA-10
Service and calibration	Ordering Code
DAkKS-Calibration (ILAC) according to DIN EN ISO/IEC 17025:2018	DAkKS-Calibration
Oxygen cleaning TCM	Oxygen cleaning TCM
Inspection certificate 3.1 according to DIN 50 049/EN 10204	3.WKZ-0100
TAG Plate 1.4404 [AISI 316L]	TCM-Tag-Plate-1.4404



## SLIP ON, PROCESS CONNECTION DIM. + FACING ACC. ANSI B16.5 INSTALLATION LENGTH IN MM [INCH]

Process connection <sup>18)</sup>	Code	TCM 0325	TCM 0650	TCM 1550	TCM 3100	TCM 5500	TCM 7900	TCM 028K	TCM 065K	TCM 230K
½" ANSI flange class 150	AA	390 [15.35]	390 [15.35]	420 [16.54]	420 [16.54]	460 [18.11]	460 [18.11]			
½" ANSI flange class 300	AB	390 [15.35]	390 [15.35]	420 [16.54]	420 [16.54]	460 [18.11]	460 [18.11]			
½" ANSI flange class 600	AC	390 [15.35]	390 [15.35]	420 [16.54]	420 [16.54]	460 [18.11]	460 [18.11]			
½" ANSI flange class 900	AD	390 [15.35]	390 [15.35]	420 [16.54]	420 [16.54]	460 [18.11]	460 [18.11]			
½" ANSI flange class 1500	BV	390 [15.35]	390 [15.35]	420 [16.54]	420 [16.54]	460 [18.11]				
½" ANSI flange class 2500	BE	390 [15.35]	390 [15.35]	420 [16.54]	420 [16.54]					
¾" ANSI flange class 150	BA	390 [15.35]	390 [15.35]	420 [16.54]	420 [16.54]	460 [18.11]	460 [18.11]			
¾" ANSI flange class 300	BB	390 [15.35]	390 [15.35]	420 [16.54]	420 [16.54]	460 [18.11]	460 [18.11]			
¾" ANSI flange class 600	BC	390 [15.35]	390 [15.35]	420 [16.54]	420 [16.54]	460 [18.11]	460 [18.11]			
¾" ANSI flange class 900	BD	390 [15.35]	390 [15.35]	420 [16.54]	420 [16.54]	460 [18.11]	460 [18.11]			
¾" ANSI flange class 1500	AI	390 [15.35]	390 [15.35]	420 [16.54]	420 [16.54]					
1" ANSI flange class 150	AE	390 [15.35]	390 [15.35]	420 [16.54]	420 [16.54]	460 [18.11]	460 [18.11]	625 [24.61]		
1" ANSI flange class 300	AF	390 [15.35]	390 [15.35]	420 [16.54]	420 [16.54]	460 [18.11]	460 [18.11]	625 [24.61]		
1" ANSI flange class 600	AG	390 [15.35]	390 [15.35]	420 [16.54]	420 [16.54]	460 [18.11]	460 [18.11]	625 [24.61]		
1" ANSI flange class 900	AH	390 [15.35]	390 [15.35]			460 [18.11]	460 [18.11]	625 [24.61]		
1" ANSI flange class 1500	AQ	390 [15.35]	390 [15.35]			460 [18.11]				
1" ANSI flange class 2500	BN	390 [15.35]	390 [15.35]							
1½" ANSI flange class 150	AJ					460 [18.11]	460 [18.11]	625 [24.61]		
1½" ANSI flange class 300	AK					460 [18.11]	460 [18.11]	625 [24.61]		
1½" ANSI flange class 600	AL					460 [18.11]	460 [18.11]	625 [24.61]		
1½" ANSI flange class 900	AM					460 [18.11]	460 [18.11]	625 [24.61]		
1½" ANSI flange class 1500	BI					460 [18.11]				

<sup>18)</sup>Connections without installation length are not possible or need manufacturer release. Please contact the manufacturer.



SLIP ON, PROCESS CONNECTION DIM. + FACING ACC. ANSI B16.5  
INSTALLATION LENGTH IN MM [INCH]

Process connection <sup>19)</sup>	Code	TCM 0325	TCM 0650	TCM 1550	TCM 3100	TCM 5500	TCM 7900	TCM 028K	TCM 065K	TCM 230K
2" ANSI flange class 150	AN							625 [24.61]	830 [32.68]	
2" ANSI flange class 300	AO							625 [24.61]	830 [32.68]	
2" ANSI flange class 600	AP							625 [24.61]	830 [32.68]	
2" ANSI flange class 900	AR							625 [24.61]	830 [32.68]	
2" ANSI flange class 1500	BU								830 [32.68]	
2½" ANSI flange class 150	BT								830 [32.68]	
2½" ANSI flange class 300	BY								830 [32.68]	
2½" ANSI flange class 600	BQ								830 [32.68]	
2½" ANSI flange class 900	BW								830 [32.68]	
3" ANSI flange class 150	AS							625 [24.61]	830 [32.68]	915 [36.02]
3" ANSI flange class 300	AT								830 [32.68]	915 [36.02]
3" ANSI flange class 600	AU								830 [32.68]	915 [36.02]
3" ANSI flange class 900	AV								830 [32.68]	915 [36.02]
4" ANSI Flange class 150	AW								830 [32.68]	915 [36.02]
4" ANSI flange class 300	AX								830 [32.68]	915 [36.02]
4" ANSI flange class 600	AY								830 [32.68]	915 [36.02]
4" ANSI flange class 900	AZ								830 [32.68]	915 [36.02]
5" ANSI flange class 150	BF									915 [36.02]
5" ANSI flange class 300	BG									915 [36.02]
5" ANSI flange class 600	BH									915 [36.02]
5" ANSI flange class 900	BJ									915 [36.02]
6" ANSI flange class 150	BM									915 [36.02]
6" ANSI flange class 600	BX									915 [36.02]

<sup>19)</sup>Connections without installation length are not possible or need manufacturer release. Please contact the manufacturer.



## SLIP ON, PROCESS CONNECTION DIM. + FACING ACC. EN 1092-1 FORM B INSTALLATION LENGTH IN MM [INCH]

Process connection <sup>20)</sup>	Code	TCM 0325	TCM 0650	TCM 1550	TCM 3100	TCM 5500	TCM 7900	TCM 028K	TCM 065K	TCM 230K
DN 10, EN flange PN 40	DS	390 [15.35]	390 [15.35]	420 [16.54]	420 [16.54]					
DN 10, EN flange PN 63	DZ	390 [15.35]	390 [15.35]	420 [16.54]	420 [16.54]					
DN 10, EN flange PN 100	EA	390 [15.35]	390 [15.35]	420 [16.54]	420 [16.54]					
DN 10, EN flange PN 160	EB	390 [15.35]	390 [15.35]	420 [16.54]	420 [16.54]					
DN 10, EN flange PN 250	EC	390 [15.35]	390 [15.35]	420 [16.54]	420 [16.54]					
DN 10, EN flange PN 400	ED	390 [15.35]	390 [15.35]	420 [16.54]	420 [16.54]					
DN 15, EN flange PN 40	DA	390 [15.35]	390 [15.35]	420 [16.54]	420 [16.54]	460 [18.11]	460 [18.11]			
DN 15, EN flange PN 63	EF	390 [15.35]	390 [15.35]	420 [16.54]	420 [16.54]	460 [18.11]	460 [18.11]			
DN 15, EN flange PN 100	DB	390 [15.35]	390 [15.35]	420 [16.54]	420 [16.54]	460 [18.11]	460 [18.11]			
DN 15, EN flange PN 160	EG	390 [15.35]	390 [15.35]	420 [16.54]	420 [16.54]	460 [18.11]				
DN 15, EN flange PN 250	EH	390 [15.35]	390 [15.35]	420 [16.54]	420 [16.54]	460 [18.11]				
DN 15, EN flange PN 400	EI	390 [15.35]	390 [15.35]	420 [16.54]	420 [16.54]	460 [18.11]				
DN 20, EN flange PN 40	DT					460 [18.11]	460 [18.11]			
DN 25, EN flange PN 40	DC	390 [15.35]	390 [15.35]	420 [16.54]	420 [16.54]	460 [18.11]	460 [18.11]	625 [24.61]		
DN 25, EN flange PN 63	EJ	390 [15.35]	390 [15.35]	420 [16.54]	420 [16.54]	460 [18.11]	460 [18.11]	625 [24.61]		
DN 25, EN flange PN 100	DD	390 [15.35]	390 [15.35]	420 [16.54]	420 [16.54]	460 [18.11]	460 [18.11]	625 [24.61]		
DN 25, EN flange PN 160	DW	390 [15.35]	390 [15.35]	420 [16.54]	420 [16.54]	460 [18.11]				
DN 25, EN flange PN 160 Mat.: 2.4602	DW							625 [24.61]		
DN 25, EN flange PN 250	DP	390 [15.35]	390 [15.35]	420 [16.54]	420 [16.54]	460 [18.11]				
DN 25, EN flange PN 400	DV	390 [15.35]	390 [15.35]			460 [18.11]				
DN 32, EN flange PN 40	DR					460 [18.11]	460 [18.11]	625 [24.61]		

<sup>20)</sup>Connections without installation length are not possible or need manufacturer release. Please contact the manufacturer.





## SLIP ON, PROCESS CONNECTION DIM. + FACING ACC. EN 1092-1 FORM B INSTALLATION LENGTH IN MM [INCH]

Process connection <sup>21)</sup>	Code	TCM 0325	TCM 0650	TCM 1550	TCM 3100	TCM 5500	TCM 7900	TCM 028K	TCM 065K	TCM 230K
DN 40, EN flange PN 40	DE					460 [18.11]	460 [18.11]	625 [24.61]		
DN 40, EN flange PN 63	EK					460 [18.11]	460 [18.11]	625 [24.61]		
DN 40, EN flange PN 100	DF					460 [18.11]	460 [18.11]	625 [24.61]		
DN 40, EN flange PN 160	EL					460 [18.11]				
DN 40, EN flange PN 250	EM					460 [18.11]				
DN 40, EN flange PN 400	EN					460 [18.11]				
DN 50, EN flange PN 16	EO							625 [24.61]	830 [32.68]	
DN 50, EN flange PN 40	DG							625 [24.61]	830 [32.68]	
DN 50, EN flange PN 63	EP							625 [24.61]	830 [32.68]	
DN 50, EN flange PN 100	DH							625 [24.61]	830 [32.68]	
DN 65, EN flange PN 16	EQ								830 [32.68]	
DN 65, EN flange PN 40	DQ								830 [32.68]	
DN 65, EN flange PN 63	ER								830 [32.68]	
DN 65, EN flange PN 100	ES								830 [32.68]	
DN 80, EN flange PN 16	ET								830 [32.68]	915 [36.02]
DN 80, EN flange PN 40	DJ								830 [32.68]	915 [36.02]
DN 80, EN flange PN 63	EU								830 [32.68]	915 [36.02]
DN 80, EN flange PN 100	DK								830 [32.68]	915 [36.02]
DN 100, EN flange PN 16	EV								830 [32.68]	915 [36.02]
DN 100, EN flange PN 40	DL								830 [32.68]	915 [36.02]
DN 100, EN flange PN 63	EW								830 [32.68]	915 [36.02]
DN 100, EN flange PN 100	DM								830 [32.68]	915 [36.02]

<sup>21)</sup>Connections without installation length are not possible or need manufacturer release. Please contact the manufacturer.



## SLIP ON, PROCESS CONNECTION DIM. + FACING ACC. EN 1092-1 FORM B INSTALLATION LENGTH IN MM [INCH]

Process connection <sup>22)</sup>	Code	TCM 0325	TCM 0650	TCM 1550	TCM 3100	TCM 5500	TCM 7900	TCM 028K	TCM 065K	TCM 230K
DN125, EN flange PN 16	EX									915 [36.02]
DN125, EN flange PN 40	DN									915 [36.02]
DN125, EN flange PN 63	EY									915 [36.02]
DN125, EN flange PN 100	DO									915 [36.02]
DN150, EN flange PN 16	DI									915 [36.02]
DN150, EN flange PN 40	DX									915 [36.02]

## EN FLANGE WELD NECK INSTALLATION LENGTH IN MM [INCH]

Process connection <sup>22)</sup>	Code	TCM 0325	TCM 0650	TCM 1550	TCM 3100	TCM 5500	TCM 7900	TCM 028K	TCM 065K	TCM 230K
DN 32, PN40 DIN 2635 – 1.4404 [AISI 316L] Type C Face	VO					460 [18.11]	460 [18.11]	625 [24.61]		
DN 32, PN64 DIN 2636 – 1.4404 [AISI 316L] Type E Face	VP					460 [18.11]	460 [18.11]	625 [24.61]		
DN 32, PN100 DIN 2637 – 1.4404 [AISI 316L] Type E Face	VQ					460 [18.11]	460 [18.11]	625 [24.61]		

## TRICLAMP INSTALLATION LENGTH IN MM [INCH]

Process connection <sup>22)</sup>	Code	TCM 0325	TCM 0650	TCM 1550	TCM 3100	TCM 5500	TCM 7900	TCM 028K	TCM 065K	TCM 230K
½" Triclamp	TA	220 [8.66]	220 [8.66]	250 [9.84]	250 [9.84]					
DN 25 Triclamp PN 16 DIN 32676	TL	210 [8.27]	210 [8.27]	240 [9.45]	240 [9.45]	460 [18.11]	460 [18.11]	625 [24.61]		

<sup>22)</sup>Connections without installation length are not possible or need manufacturer release. Please contact the manufacturer.



FEMALE THREAD  
INSTALLATION LENGTH IN MM [INCH]

Process connection <sup>23)</sup>	Code	TCM 0325	TCM 0650	TCM 1550	TCM 3100	TCM 5500	TCM 7900	TCM 028K	TCM 065K	TCM 230K
¼" NPT female thread	FJ	110 [4.33]	110 [4.33]	140 [5.51]	140 [5.51]					
¾" NPT female thread	FL	110 [4.33]	110 [4.33]	140 [5.51]	140 [5.51]	460 [18.11]	460 [18.11]			
½" NPT female thread	FK	110 [4.33]	110 [4.33]	140 [5.51]	140 [5.51]	460 [18.11]	460 [18.11]			
2" NPT female thread	FQ								880 [34.65]	
¼" G. female thread	FB	110 [4.33]	110 [4.33]	140 [5.51]	140 [5.51]					
¾" G, female thread	FR	110 [4.33]	110 [4.33]	140 [5.51]	140 [5.51]					
¾" G, female thread	FC	110 [4.33]	110 [4.33]	140 [5.51]	140 [5.51]	460 [18.11]	460 [18.11]			
½" G, female thread	FA	110 [4.33]	110 [4.33]	140 [5.51]	140 [5.51]	460 [18.11]	460 [18.11]			

<sup>23)</sup>Connections without installation length are not possible or need manufacturer release. Please contact the manufacturer.



## NORTH & SOUTH AMERICA

AW-Lake Company  
2440 W. Corporate Preserve Dr. #600  
Oak Creek WI 53154 | USA  
+1 414 574 4300  
[sales@aw-lake.com](mailto:sales@aw-lake.com)  
[www.aw-lake.com](http://www.aw-lake.com)

## ASIA PACIFIC & MIDDLE EAST

KEM Küppers Elektromechanik GmbH  
73 Science Park Drive  
#01-08/09 Cintech 1  
Singapore 118254  
+65 6347 6162  
[singapore@kem-kueppers.com](mailto:singapore@kem-kueppers.com)  
[www.kem-kueppers.cn](http://www.kem-kueppers.cn)

## EUROPE (ROW)

KEM Küppers Elektromechanik GmbH  
Liebigstraße 5  
85757 Karlsfeld | Germany  
+49 8131 59391-100  
[sales@kem-kueppers.com](mailto:sales@kem-kueppers.com)  
[www.kem-kueppers.com](http://www.kem-kueppers.com)

## CHINA

KEM flow technology (Beijing) Co., Ltd.  
Rm. 906, Block C, Ruipu Office Bldg, No. 15  
HongJunYingNan Road  
Chaoyang District, Beijing 100012 | China  
+86 10 84929567  
[sales@kem-kueppers.com](mailto:sales@kem-kueppers.com)  
[www.kem-kueppers.cn](http://www.kem-kueppers.cn)



株式会社 **クローネ**

本 社：〒124-0023 東京都葛飾区東新小岩3丁目9番6号 TEL: (03) 3695-5431 / FAX: (03) 3695-5698  
大阪支店：〒530-0054 大阪市北区南森町2-2-9(南森町八千代ビル7F) TEL: (06) 6361-4831 / FAX: (06) 6361-9360  
e-mail: [sales-tokyo@krone.co.jp](mailto:sales-tokyo@krone.co.jp) URL: <https://www.krone.co.jp>

■カタログに掲載してある製品の色は印刷インキの関係上、実際とは異なる場合があります。  
■製品のデザイン、仕様等などは、予告なく変更する場合があります。