



Gear Wheel Flowmeter for viscous liquids



measuring
•
monitoring
•
analysing

DZR



- Measuring range:
0.008 - 2 ... 3-700 l/min
- Accuracy:
 $\pm 0.3 \dots \pm 1\%$ of reading
- p_{\max} : 400 bar
- t_{\max} : 150 °C
- Process connection:
G 1/8, G 3/8, G 1/2, G 1 female
- Material:
cast iron or stainless steel

S4



KOBOLD companies worldwide:

AUSTRALIA, AUSTRIA, BELGIUM, BULGARIA, CANADA, CHINA, CZECHIA, EGYPT, FRANCE, GERMANY, GREAT BRITAIN, HUNGARY, INDIA, INDONESIA, ITALY, MALAYSIA, MEXICO, NETHERLANDS, PERU, POLAND, REPUBLIC OF KOREA, ROMANIA, RUSSIA, SPAIN, SWITZERLAND, THAILAND, TUNISIA, TURKEY, USA, VIETNAM

KOBOLD Messring GmbH
Nordring 22-24
D-65719 Hofheim/Ts.
Head Office:
+49(0)6192 299-0
+49(0)6192 23398
info.de@kobold.com
www.kobold.com



Description

The KOBOLD Gear Wheel Flowmeter series DZR have been designed for a flow measurement for viscous liquids. The measuring unit consists of a pair of gear wheels which is moved by the flow according to the principle of gear wheel motor. The bearings are – according to the material combination – either ball bearings or gliding bearings.

The movement of the gears is sampled without contact by means of two sensors located in the cover. Between sensor compartment and measuring chamber is located a pressure-resistant, non-magnetic separator plate.

The different versions vary through housing materials, bearing assembly, through the medium being used and the accuracy. The mounting position and flow direction is arbitrary.

Version

- DZR-1 Flow measurement, hydraulic test rigs for: Oil, brake fluid, Diesel, Skydrol lubricating, low viscous
- DZR-2 Oil batching, batching installations gear box oil, lubricating, mid viscous
- DZR-3 Consumption measurement printing machines, offset colour, lubricating, high viscous
- DZR-4 Ratio control, 2-component plant, Polyol, Isocyanate, glue, resin, silicone, low lubricating, mid viscous
- DZR-5 Batch control, painting plant, clear paint, clearance volume sealing, low lubricating, mid viscous
- DZR-6 Flow measurement, painting plant, solvent, lubricating, mid viscous

Technical Details

Accuracy:	see specifications table
Recommended filter size:	20 µm
Repeatability:	<0.1% of measured value
Max. pressure:	400 bar (DZR-x001 ... DZR-x010 and DZR-x017/-x018) 315 bar (DZR-x011 ... DZR-x015)
Max. pressure loss:	$\Delta p = 16$ bar
Media temperature:	see specifications table
Ambient temperature:	-15 ... +80 °C (seal: FPM) -30 ... +80 °C (other seals)
Viscosity range:	1 ... 1 000 000 mm ² /s, according to the flow rate. The max. pressure loss of 16 bar must not be exceeded. See pressure loss diagrams.

Materials

Housing:	
DZR-1/2/3/4:	globular iron EN-GJS-400-15
DZR-5/6:	stainless steel 1.4404
Gear wheels:	
DZR-1/2/3/4:	steel 1.7139
DZR-5/6:	stainless steel 1.4462
Bearings:	see specifications table
Seals:	FPM, EPDM or FEP

Electrical data

Output signal:	2 pulse output signals 90° ± 30° phase shift
Pulse form:	rectangular duty cycle 1:1 (±15%), short circuit proof, signal PNP
Pulse amplitude:	≥ 0.8 U _S
Supply voltage U _S :	24 V _{DC} (±20%) 12 V _{DC} (±20%) (option) reversed polarity protection

Max. power consumption:	0.9 W
Max. output capacity:	0.3 W
Electric connection:	plug acc. DIN 43650
Protection:	IP 65
Weight:	see dimensions table

Plug-on display

Display:	4-digit LED display digit height 7.62 mm with floating point
Protection:	IP 65
Electrical connection:	plug acc. DIN 43650 (4 pin)
Fluid temperature:	0 ... 80 °C
Ambient temperature:	0 ... 60 °C
Max. current consumption:	120 mA
Analogue output (option 3):	0-20 mA, 4-20 mA max. load 250 Ω (18 V _{DC}) 50 Ω (10 V _{DC})
Relay contact (option 4):	2×N.O. max. 24 V / 1 A



Fluid Temperature

Model	Sealing material		
	FPM	EPDM	FEP
DZR-1/2/6	-15...+120 °C	-30...+120 °C	-30...+120 °C
DZR-3/4/5	-15...+80 °C	-30...+80 °C	-30...+80 °C
DZR-1/2/6 (Electronic H or T)	-15...+150 °C	-30...+130 °C	-30...+150 °C

Higher fluid temperature up to +220 °C on request

Pulse Output Rate

Model	Resolution [pulses/l]
DZR-x001/-x002	40000
DZR-x003	25000
DZR-x004	10000
DZR-x005	4082
DZR-x006/-x007	2500
DZR-x008/-x009/-x010	965
DZR-x011/-x012	333
DZR-x013/-x014/-x015	191.5
DZR-x017	83.3
DZR-x018	62.5

Specifications

	DZR-1	DZR-2	DZR-3	DZR-4	DZR-5	DZR-6
Media viscosity	low	medium	high	medium	medium	low
Lubrication properties of media	good	good	good	bad	bad	good
Max. particle size	<20 µm	<20 µm	<50 µm	<30 µm	<30 µm	<20 µm
Bearing	ball bearing	ball bearing	bronze gliding bearing	tungsten c.gl. bearing	tungsten c.gl. bearing	ball bearing
Material	cast iron	cast iron	cast iron	cast iron	stainless steel	stainless steel
Accuracy of measured value	±0.3% from 20 mm ² /s	±0.5% from 50 mm ² /s	±1% from 100 mm ² /s	±0.5% from 100 mm ² /s	±0.5% from 100 mm ² /s	±0.3% from 20 mm ² /s
	Start of rotation with 20 mm ² /s at approx. [l/min]	Measuring range [l/min]				
001	0.001	0.008...2	-	-	-	0.008...2
002	0.001	-	-	-	0.02...2*	-
003	0.004	0.02...4	-	-	-	0.02...4
004	0.01	0.04...8	-	-	0.04...8	0.04...8
005	0.01	0.16...16	0.16...16	-	0.16...16	0.16...16
006	0.01	-	-	-	0.2...30	-
007	0.01	0.2...40	-	-	-	-
008	0.02	-	-	0.6...40	-	-
009	0.02	-	-	-	0.3...60	0.3...60
010	0.02	0.4...80	0.4...80	-	-	0.4...80
011	0.03	-	-	-	0.6...100	0.6...100
012	0.03	0.6...160	-	-	-	0.6...160
013	0.04	-	-	1.2...80	-	-
014	0.04	-	-	-	1...160	1...160
015	0.04	1...250	1...250	-	-	1...250
017	0.1	2...600	-	-	-	-
018	0.2	3...700	-	-	-	-

* Accuracy: ±3%, linearity ±1.5%



Gear Wheel Flowmeter for viscous liquids Model DZR

Oder Details (Example: **DZR-1 001 S10 F S 0**)

Model	Range ¹⁾	Mech. connection (female thread)	Seal	Sensor ⁴⁾	Electronic electr. connection	
DZR-1	001	S10 = G 3/8 side H10 = G 3/8 back	F = FPM E = EPDM P = FEP	S = up to 120°C/ 24 V _{DC} H ²⁾ = up to 150°C/ 24 V _{DC} R = up to 120°C/ 12 V _{DC} T ²⁾ = up to 150°C/ 12 V _{DC}	V = mating plug without cable with pre amplifier 1 = mating plug with 5 m cable with pre amplifier 2 = mating plug with 10 m cable with pre amplifier 3 ³⁾ = plug-on display with 0(4) ... 20 mA output 4 ³⁾ = plug-on display with 2 x relay contacts	
	003					
	004					
	005					
DZR-1	007	S15 = G 1/2 side				
	010	H15 = G 1/2 back				
DZR-1	012	S25 = G 1 side				
	015	H25 = G 1 back				
DZR-1	017	S40 = flange SAE 1 1/2" side				
	018					
DZR-2	005	S10 = G 3/8 side H10 = G 3/8 back				with connection assembly
	010	S15 = G 1/2 side H15 = G 1/2 back				
	015	S25 = G 1 side H25 = G 1 back				
DZR-3	008	S15 = G 1/2 side H15 = G 1/2 back				
	013	S25 = G 1 side H25 = G 1 back				
DZR-4	004	S10 = G 3/8 side				
	005	H10 = G 3/8 back				
	006	S15 = G 1/2 side				
	009	H15 = G 1/2 back				
DZR-4	011	S25 = G 1 side				
	014	H25 = G 1 back				
DZR-5	002	R06 = G 1/8 side	without connection assembly			
	005	R10 = G 3/8 side				
	009	R15 = G 1/2 side				
	011	R25 = G 1 side				
014						
DZR-6	001	R06 = G 1/8 side				
	003	R08 = G 1/4 side				
	004	R10 = G 3/8 side				
	005					
	010	R15 = G 1/2 side				
	012	R25 = G 1 side				
015						

¹⁾ The range of the corresponding model can be taken from the schedule »Specifications«

²⁾ Electronic H/T only for DZR-1, DZR-2, DZR-6, not possible with plug-on display

³⁾ Max. fluid temperature 80 °C

⁴⁾ Pay attention to temperature limits due to sealing material selection



Pressure Loss Diagrams

DZR-1001, DZR-6001

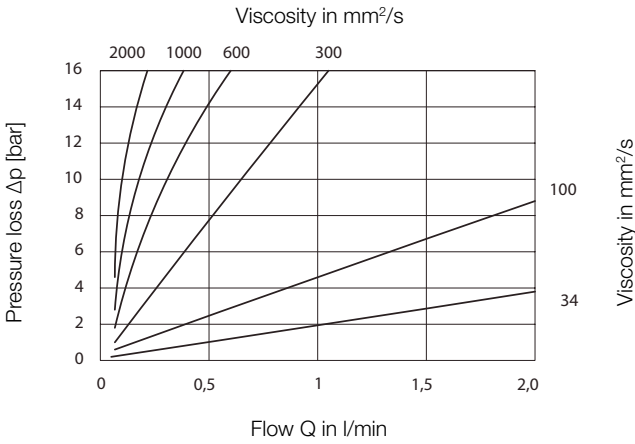

DZR-1003

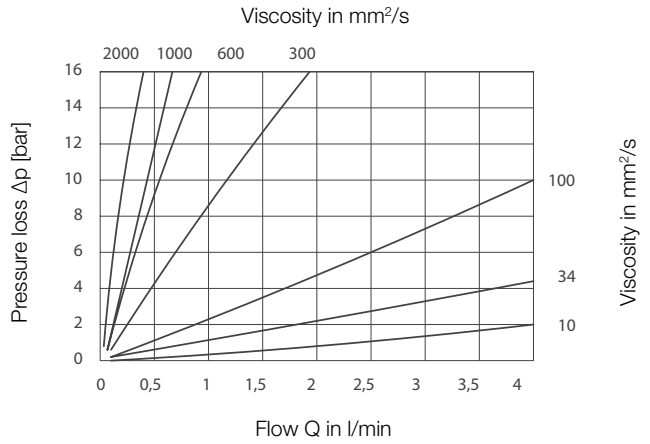

DZR-1004, DZR-4004, DZR-6004

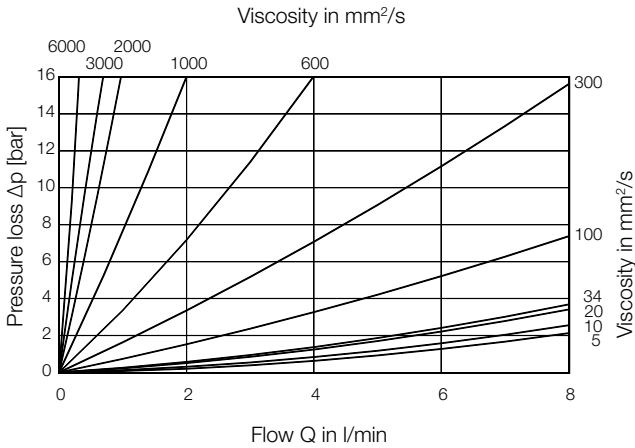

DZR-1005, DZR-2005, DZR-6005

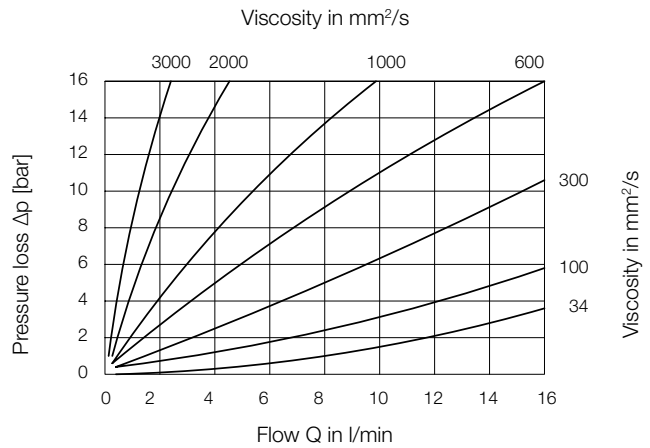

DZR-1007

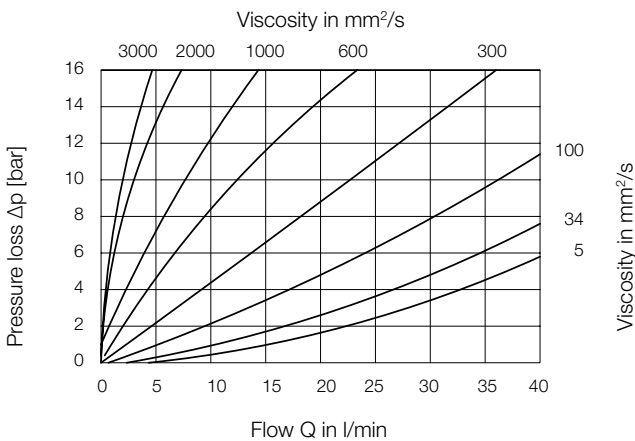

DZR-1010, DZR-2010, DZR-6010

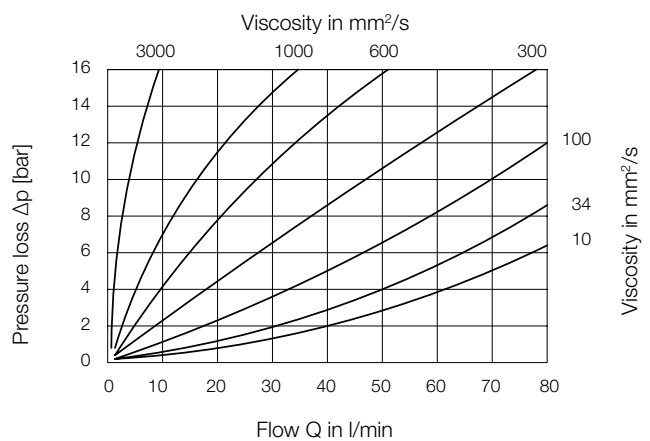



DZR-1012, DZR-6012

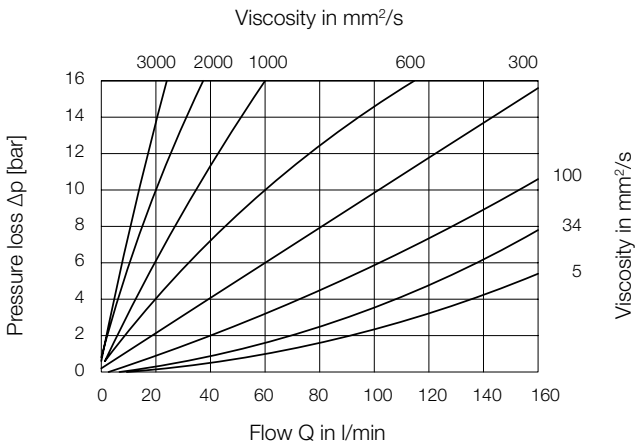

DZR-1015, DZR-2015, DZR-6015

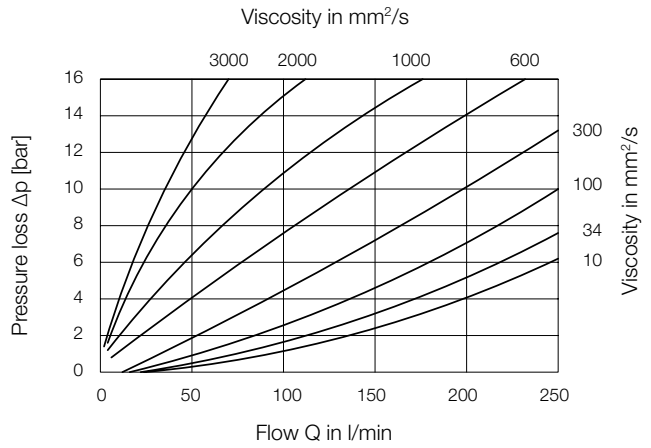

DZR-1017

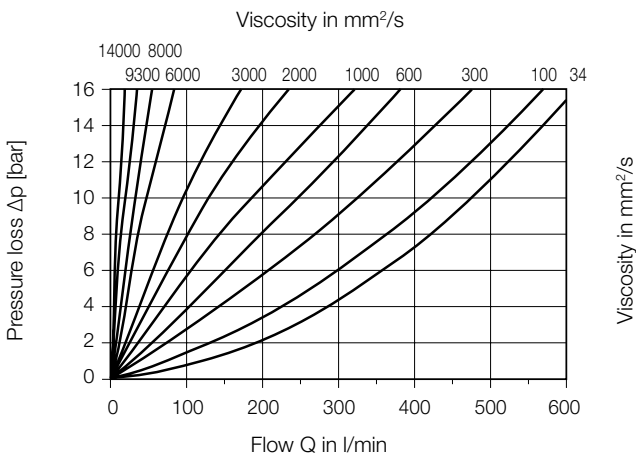

DZR-1018

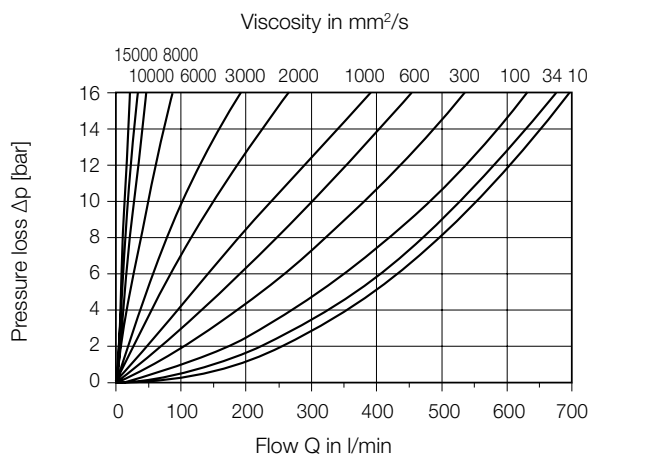

DZR-3008

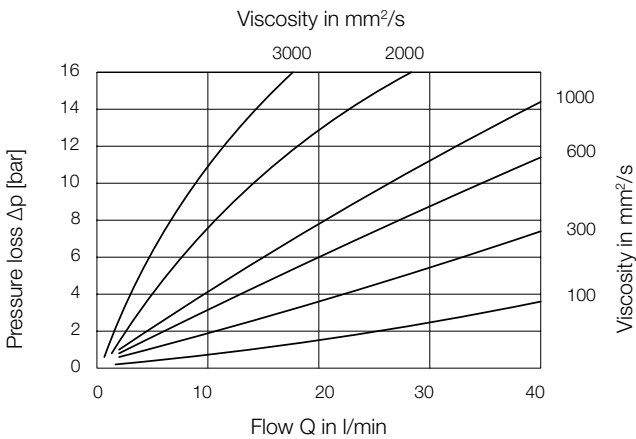

DZR-3013

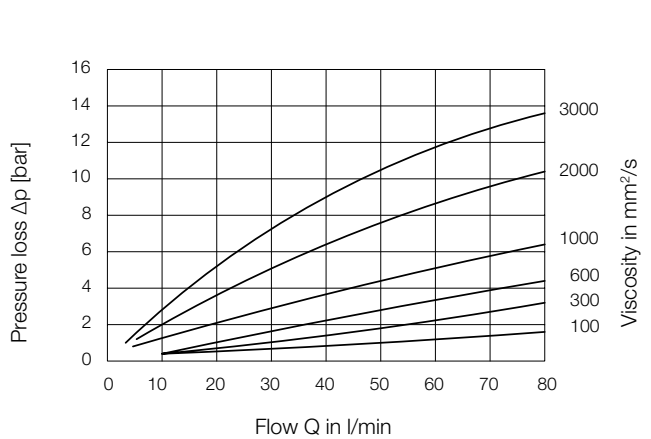

DZR-4005, DZR-5005

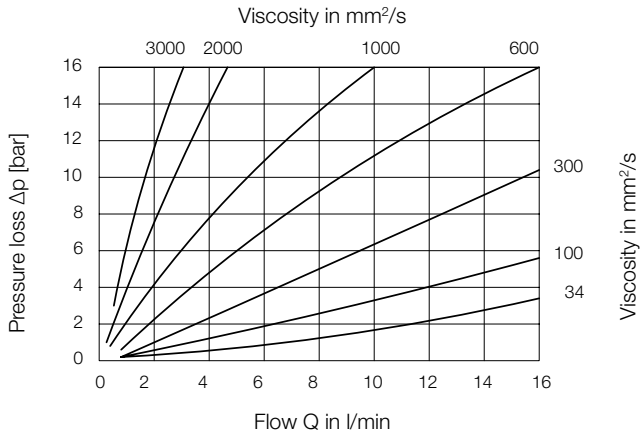

DZR-4006

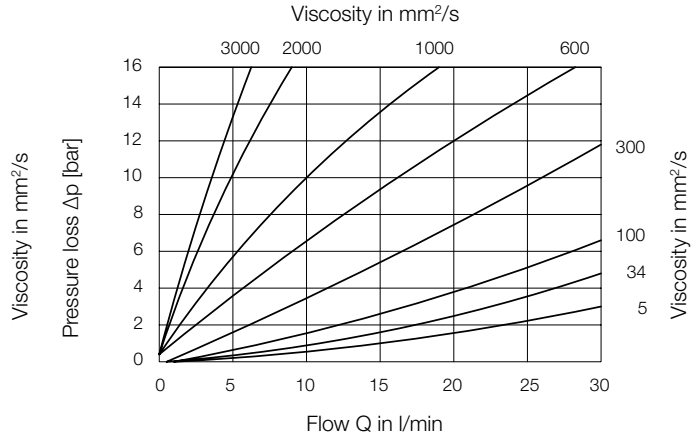

DZR-4009, DZR-5009

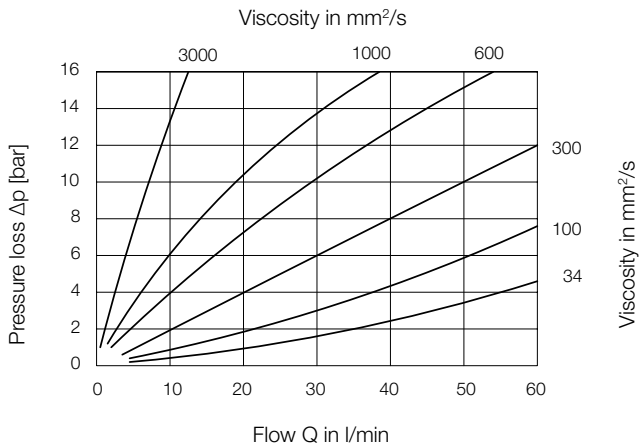

DZR-4011, DZR-5011

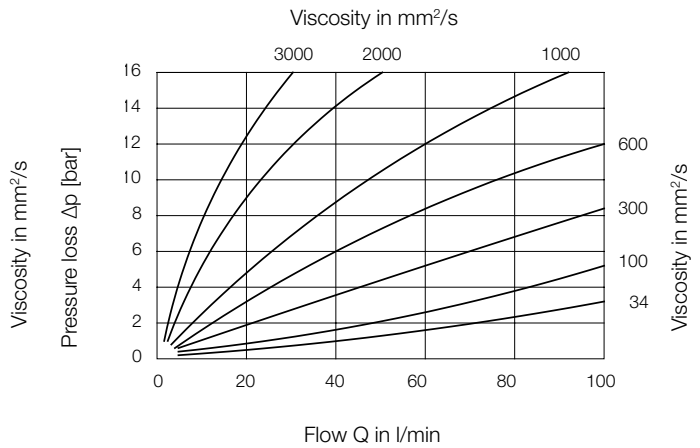

DZR-4014, DZR-5014

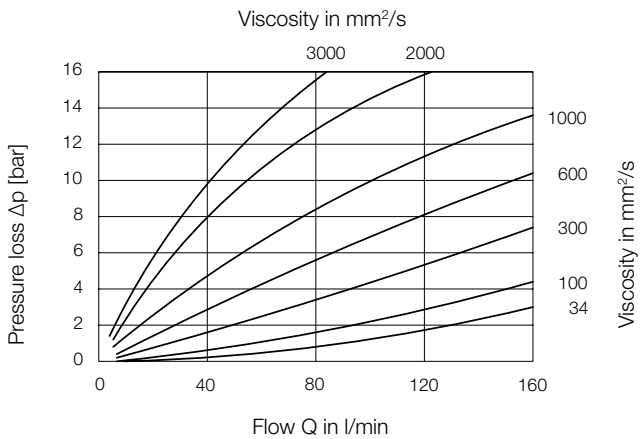

Dimensions of plug-on display (Option 3, 4) [mm]

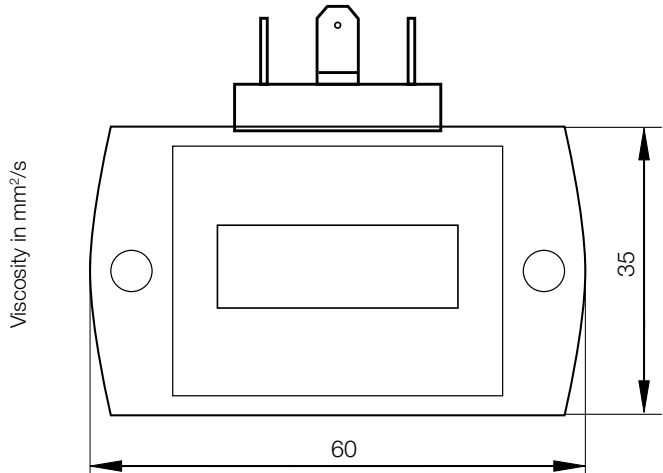



Gear Wheel Flowmeter for viscous liquids Model DZR

Dimensions DZR-1, DZR-2, DZR-3, DZR-4, without connection assembly

Measuring range code	Weight [kg]	Dimensions [mm]											
		A	C	D	F	G _S	G _H	J	K	L	M	N	P
001/002	1.8	85	10	60	50	101	114	-	70	40	20	6.5	M6
003	2	85	9	60	56	107	120	-	70	40	20	6.5	M6
004	2	85	9	60	56	107	120	-	70	40	20	6.5	M6
005	2	85	13	60	57	108	121	-	70	40	20	9	M6
006/007	3.7	100	17	90	63	114	127	-	80	38	34	16	M8
008/009/010	5.2	120	13	95	72	123	136	15.5	84	72	35	16	M8
011/012	9	170	18	120	89	140	153	46.5	46	95	50	25	M12
013/014/015	13	170	22	120	105	156	169	46.5	46	95	50	25	M12

DZR-1, DZR-2, DZR-3, DZR-4 without connection assembly

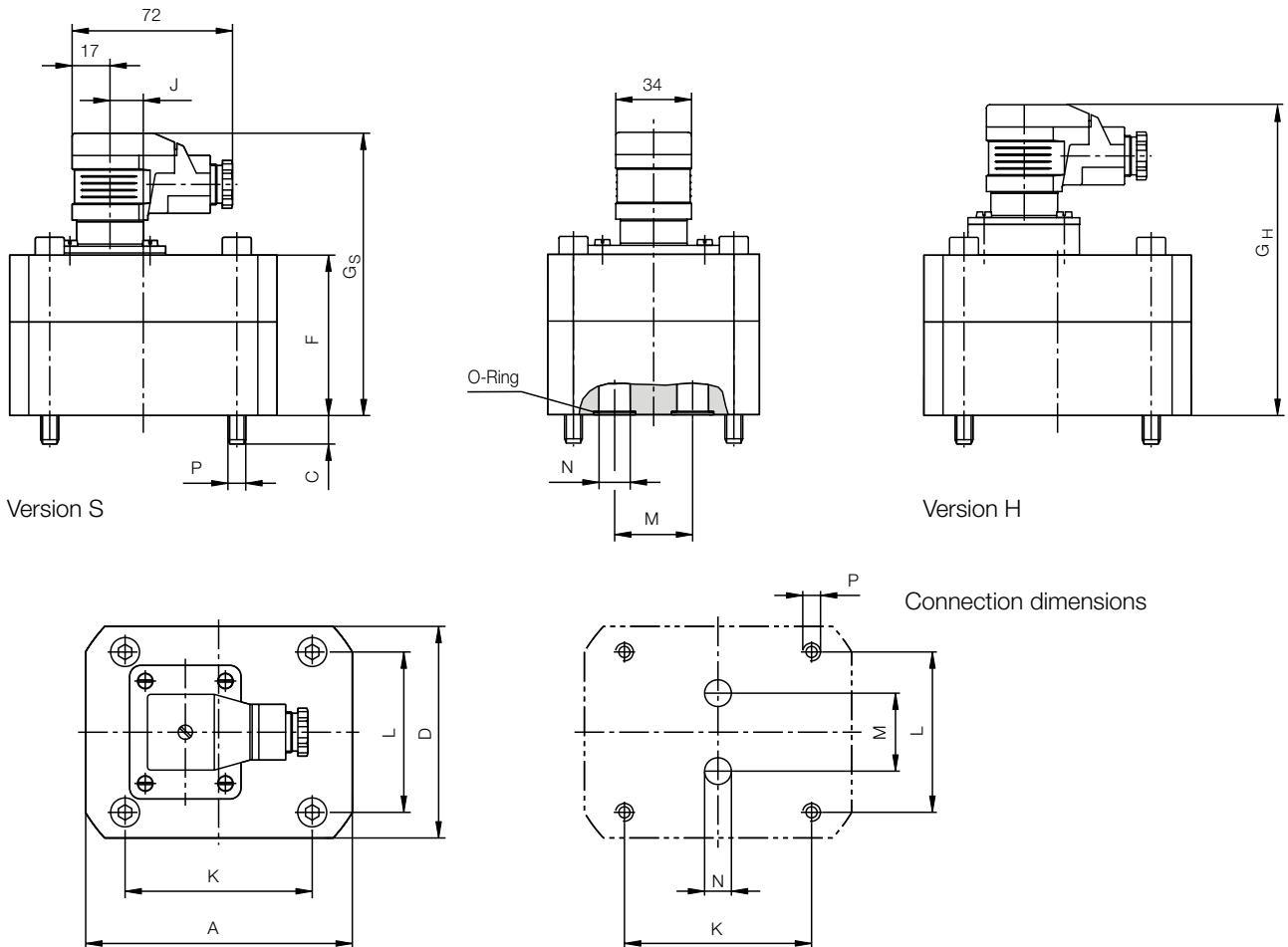

Dimensions DZR-1

Measuring range code	Weight [kg]	Dimensions [mm]										
		m	C	D	F	G _S	G _H	J	K	L	M	N
017	53.5	44	249	168	219	232	77	120	140	70	38	M20
018	57.4	44	249	184	235	248	77	120	140	70	38	M20

Standard temperature version S and R

High temperature version H and T

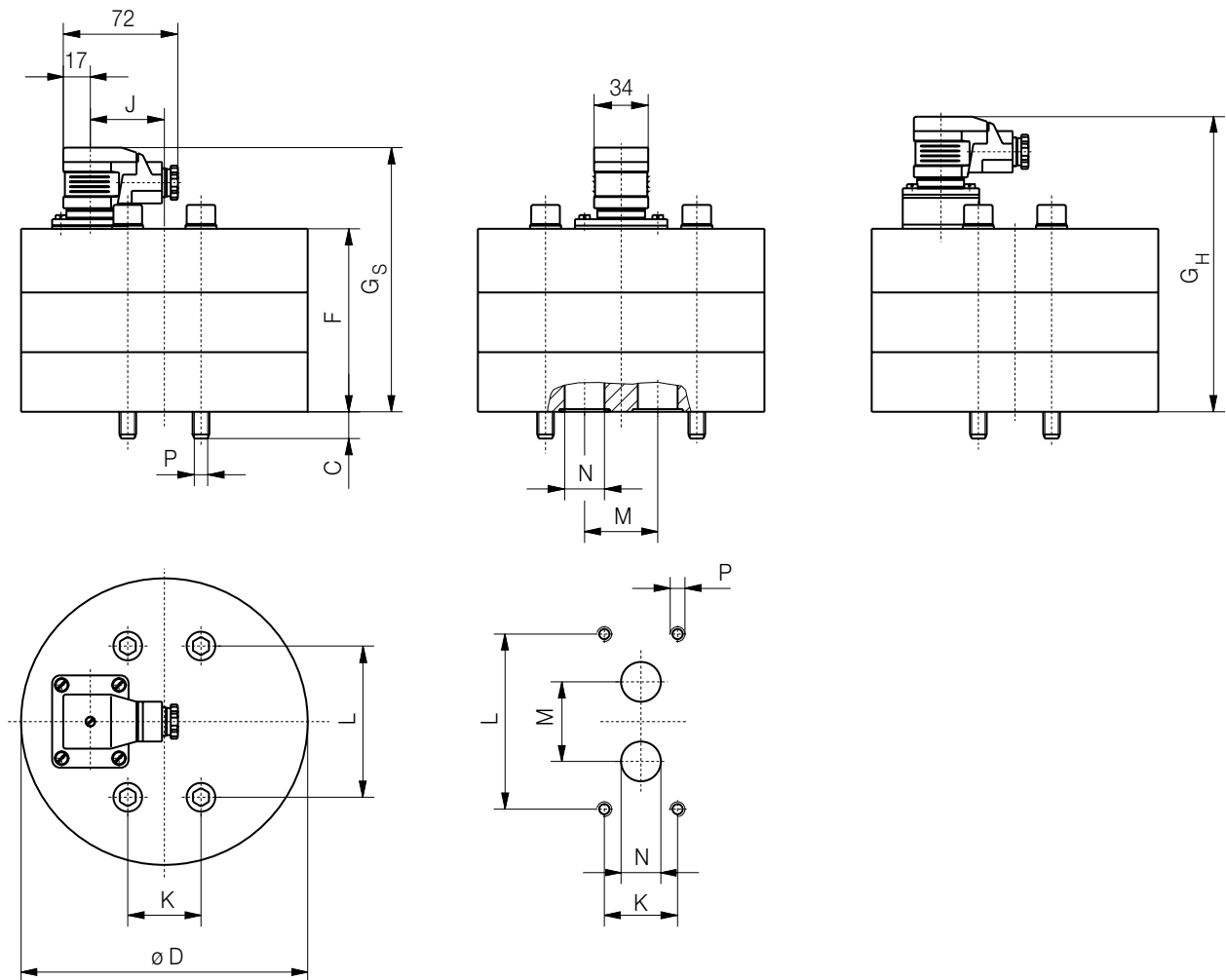

Dimensions of connection assembly for DZR-1, DZR-2, DZR-3, DZR-4

Side connection

Meas. range code	Weight [kg]	Dimensions [mm]																	
		A	B	C	E	F	G	H	J	K	L	M	N	P	R	c	d	e	f
001-005	1.8	85	90	35	65	76	7	11	7	70	40	20	6,5	M6/14t	17	0.7	25	G $\frac{3}{8}$	13
006-007	2.7	100	110	37	86	96	7	11	7	80	38	34	16	M8/18t	18.5	0.7	29	G $\frac{1}{2}$	15
008-010	2.9	100	120	37	80	106	7	11	7	84	72	35	12	M8/18t	17.5	0.7	29	G $\frac{1}{2}$	15
011-015	14	160	165	80	140	145	9	15	9	46	95	50	25	M12/24t	28	1	42	G1	19

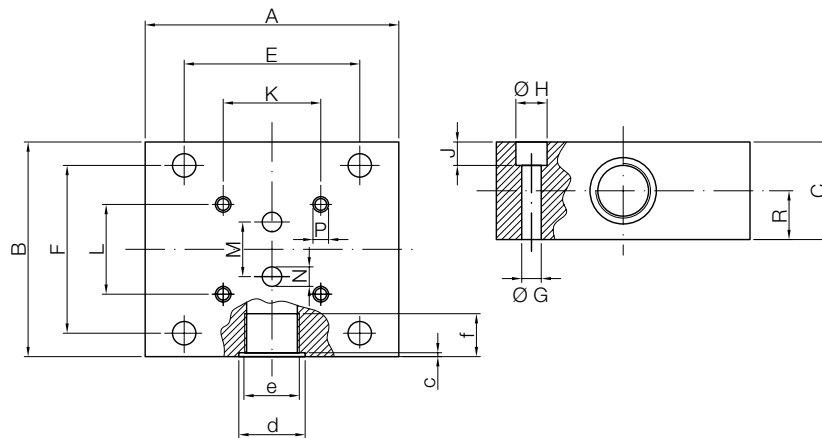

Connection back

Meas. range code	Weight [kg]	Dimensions [mm]																	
		A	B	C	E	F	G	H	J	K	L	M	N	P	R	c	d	e	f
001-005	1.6	85	90	35	65	76	7	11	7	70	40	20	6,5	M6/14t	28	0.7	25	G $\frac{3}{8}$	13
006-007	2.5	100	110	37	86	96	7	11	7	80	38	34	16	M8/18t	46	0.7	29	G $\frac{1}{2}$	15
008-010	2.7	100	120	37	80	106	7	11	7	84	72	35	12	M8/18t	50	0.7	29	G $\frac{1}{2}$	15
011-015	9.6	160	165	55	140	145	9	15	9	46	95	50	25	M12/24t	55	1	42	G1	19

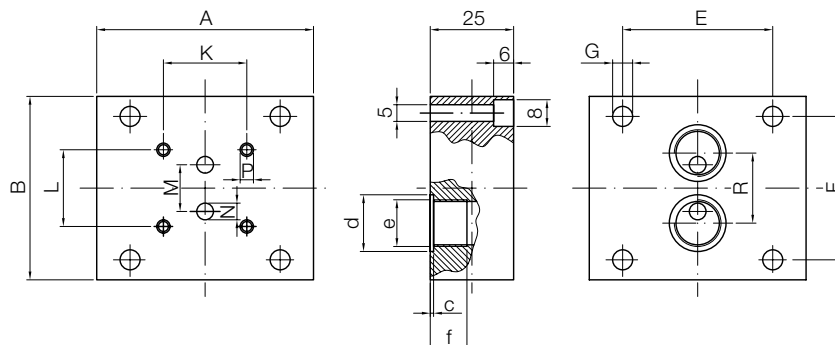

Dimensions of connection assembly for DZR-1 / connection sideways

Meas. range code	Weight [kg] m	Dimensions [mm]															
		A	B	C	E	F	G	K	L	M	N	P	R	a	b	e	f
017/018	41.2	249	200	140	120	140	M10/20t	120	140	70	38	M20/45t	70	79.4	36,5	38	M16/25t

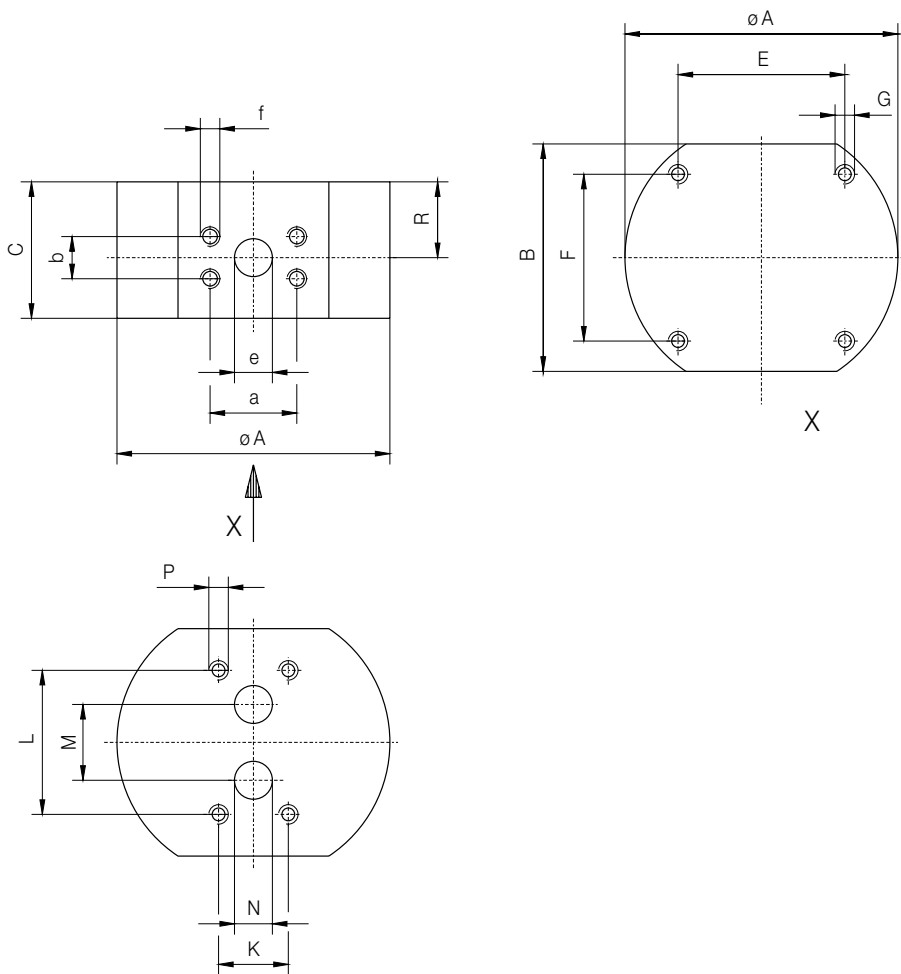



Gear Wheel Flowmeter for viscous liquids Model DZR

Dimensions DZR-5, DZR-6

Meas. range code	Weight [kg]	Dimensions [mm]												
		A	B	C	D	E	F	G _S	G _H	H	J	K	L	P
001-002	3	G $\frac{1}{4}$	9	17	94	86	55	106	119	15	-	70	40	6.7
004-005	3.1	G $\frac{3}{8}$	13	25	94	90	57	108	121	16	-	70	40	6.7
008-010	7	G $\frac{1}{2}$	15	29	124	120	72	123	136	22	15.5	84	72	9
011-012	15.9	G1	19	42	170	162	89	140	153	30	46.5	46	50	13
013-015	18.7	G1	19	42	170	162	105	156	169	30	46.5	46	50	13

with sensor ... S/R/A without plug-on display

with sensor ... H/T without plug-on display

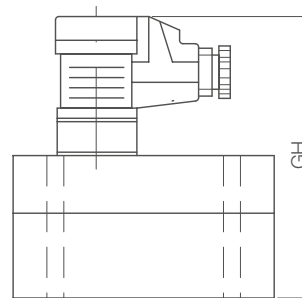
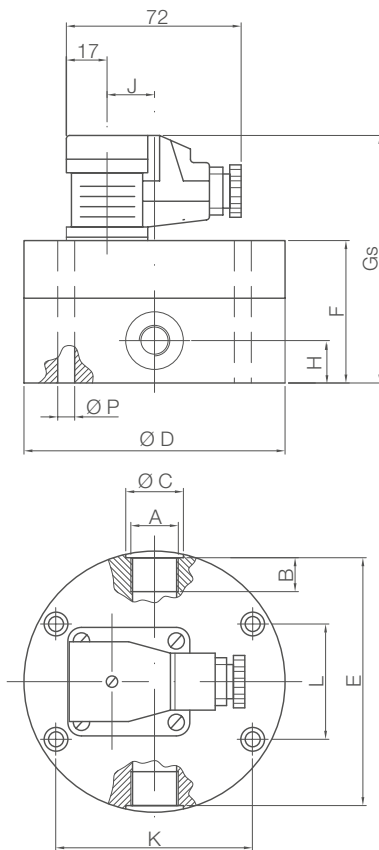

株式会社 **クローネ**

■カタログに掲載してある製品の色は印刷インキの関係上、実際とは異なる場合があります。
 ■製品のデザイン、仕様等などは、予告なく変更する場合があります。

本 社：〒124-0023 東京都葛飾区東新小岩3丁目9番6号 TEL: (03) 3695-5431 / FAX: (03) 3695-5698
 大阪支店：〒530-0054 大阪市北区南森町2-2-9(南森町八千代ビル7F) TEL: (06) 6361-4831 / FAX: (06) 6361-9360
 e-mail: sales-tokyo@krone.co.jp URL: https://www.krone.co.jp