

- Low Noise: $7 \mu\text{g}/\sqrt{\text{Hz}}$ Typical for 2g Full Scale Version
- Superior Bias & Scale Factor Temperature Coefficients
- Responds to Frequencies from Zero (DC) to 2000+ Hz
- -55 to +125°C Operation
- $\pm 4\text{V}$ Differential Analog Output
- +5 VDC, 5 mA Power (Typical)
- Integrated Sensor & Amplifier
- Internal Temperature Sensor
- Nitrogen Damped
- Hermetically Sealed
- Serialized for Traceability & RoHS Compliant



AVAILABLE G-RANGES

FULL SCALE ACCELERATION	20 PIN LCC
$\pm 2 \text{ g}$	1522L-002
$\pm 5 \text{ g}$	1522L-005
$\pm 10 \text{ g}$	1522L-010
$\pm 25 \text{ g}$	1522L-025
$\pm 50 \text{ g}$	1522L-050
$\pm 100 \text{ g}$	1522L-100
$\pm 200 \text{ g}$	1522L-200
$\pm 400 \text{ g}$	1522L-400

DESCRIPTION

The Model 1522 is a low-cost, general-purpose integrated MEMS accelerometer with enhanced performance over temperature for use in zero to medium frequency industrial applications experiencing large or rapid temperature variations or maintaining hot or cold extremes for extended periods of time. The Model 1522 accelerometers are individually tested, programmed, calibrated and verified in a climate chamber to ensure the greatest accuracy in even thermally volatile conditions.

Each miniature, hermetically sealed package combines a MEMS capacitive sense element and a custom integrated circuit that includes a sense amplifier and differential output stage. Each device is marked with a serial number on its top and bottom surfaces for traceability. A calibration test report is supplied with each unit showing the measured bias, scale factor, linearity, operating current, & frequency response.



ZERO (DC) TO MEDIUM FREQUENCY APPLICATIONS



PERFORMANCE

INPUT RANGE	SENSITIVITY, DIFFERENTIAL	FREQUENCY RESPONSE (TYPICAL, 5%)	FREQUENCY RESPONSE (TYPICAL, 3 DB)	FREQUENCY RESPONSE (MINIMUM, 3 DB)	OUTPUT NOISE, DIFFERENTIAL (RMS, TYPICAL)	MAX. MECHANICAL SHOCK (0.1 MS)
g	mV/g	Hz	Hz	Hz	$\mu\text{g}/(\text{root Hz})$	g (peak)
± 2	2000	0 - 250	0 - 525	0 - 300	7	2000
± 5	800	0 - 400	0 - 800	0 - 420	12	
± 10	400	0 - 700	0 - 1100	0 - 660	18	
± 25	160	0 - 1300	0 - 1750	0 - 1050	25	
± 50	80	0 - 1600	0 - 2100	0 - 1400	50	
± 100	40	0 - 1700	0 - 3000	0 - 1700	100	5000
± 200	20	0 - 1900	0 - 3600	0 - 2100	200	
± 400	10	0 - 2000	0 - 4200	0 - 2400	400	

By Model: $V_{DD}=V_R=5.0 \text{ VDC}$, $T_C=25^\circ\text{C}$

Single ended sensitivity is half of values shown.

SPECIFICATIONS SUBJECT TO CHANGE WITHOUT NOTICE



PERFORMANCE - ALL VERSIONS

All Models: Unless otherwise specified $V_{DD}=V_R=5.0$ VDC, $T_C=25^\circ\text{C}$, Differential. Span = $\pm g$ range = 8000 mV

PARAMETER	MIN	TYP	MAX	UNITS
Bias Calibration Error (mV)		16	40	\pm mV
Bias Calibration Error (Span)		0.2	0.5	\pm % of span
Bias Temperature Shift ($T_C= -55$ to $+125^\circ\text{C}$)	-50	0	+50	(PPM of span)/ $^\circ\text{C}$
Scale Factor Calibration Error ¹		0.5	1	\pm %
Scale Factor Temperature Shift ($T_C= -55$ to $+125^\circ\text{C}$)	-100	0	+50	PPM/ $^\circ\text{C}$
Non-Linearity (-90 to +90% of Full Scale) ¹		0.10	0.25	\pm % of span
Long Term Bias Stability		1000	2000	\pm PPM of span
Long Term Scale Factor Stability		500	1000	\pm PPM
Cross Axis Sensitivity		2	3	\pm %
Input Axis Misalignment		5	10	\pm mrad
Turn-On Transient (in less than 0.5ms)		75		\pm PPM of FS
Output Impedance		90		Ohms
Operating Voltage ²	4.75	5.0	5.25	volts
Operating Current (IDD+IVR)		5.5	6.5	mA
Mass: 'L' package		0.62		grams
Case Operating Temperature	-55 to $+125^\circ\text{C}$	Voltage on V_{DD} to GND		-0.5V to 6.0V
Storage Temperature	-55 to $+125^\circ\text{C}$	Voltage on Any Pin (except DV) to GND ³		-0.5V to $V_{DD}+0.5V$
Max Reflow Solder Temperature	$+239^\circ\text{C}$	Voltage on DV to GND (Self-Test)		$\pm 15V$
Power Dissipation		35 mW		

Note 1: For 2g thru 50g only; 100g and greater versions are tested and specified from -65 to +65g.

Note 2: Voltages on pins other than DV, GND or V_{DD} may exceed 0.50 volt above or below the supply voltages provided max current is <1 mA.

NOTICE: Minimize exposure above 125°C for maximum lifespan. Stresses greater than those listed above may cause permanent damage to the device. These are maximum stress ratings only. Functional operation of the device at or above these conditions is not implied. Exposure to absolute maximum rating conditions for extended periods may affect device reliability and lifespan.

BIAS & SCALE FACTOR TEMPERATURE SHIFT EXPLAINED

Every accelerometer has a bias and scale factor temperature coefficient, meaning the output shifts slightly due to temperature changes. Many applications operate within a relatively small temperature band or at room temperature, and therefore rarely encounter interference from the bias or scale factor temperature shifts. For applications experiencing larger temperature variations SDI suggests the upgraded High-Performance 1522 accelerometer. These are temperature compensated, and then individually tested, calibrated and verified in a climate chamber to ensure enhanced performance.

Bias	The accelerometer output with no acceleration present. For SDI's differential output analog accelerometers, it is a signed quantity that is expressed in terms of either g or output volts and is ideally equal to zero g or zero volts.
Scale Factor	The ratio of the change in output to a unit change in the input acceleration expressed in millivolts per g (mV/g). Since the output of most accelerometers is slightly non-linear, the scale factor value is defined as the slope of the least-squares-fit line to the acceleration input vs output curve. SDI measures over the range of -90% to +90% of full scale or from -65g to +65g, whichever is smaller.
Bias Temperature Shift (Coefficient)	The amount of bias shift to expect with a change in temperature expressed as PPM of span per $^\circ\text{C}$. For example, the percent of span bias shift that would occur for a 25g full scale device with a +/-200 PPM of span per $^\circ\text{C}$ rating and a 55 $^\circ\text{C}$ rise from room temperature would be: $\pm 200 / 1,000,000 \times (80\text{C} - 25\text{C}) \times 100\%$ of span = $\pm 1.1\%$ of span. The g shift would be $\pm 1.1\%$ of 50g = 0.55 g. This error in terms of output voltage for a 25 g analog accelerometer would be $\pm 1.1\%$ of span = $\pm 1.1\%$ of 8 V = 88 mV.
Scale Factor Temperature Shift (Coefficient)	The amount of scale factor shift to expect with a change in temperature expressed as PPM per $^\circ\text{C}$. For example, the percent shift in scale factor that would occur for a device with a +200 PPM per $^\circ\text{C}$ rating and a 60 $^\circ\text{C}$ rise from room temperature would be: $\pm 200 / 1,000,000 \times (85\text{C} - 25\text{C}) \times 100\%$ = +1.2%. For an analog 10g device, the scale factor would rise from its nominal (8 V)/(20 g) = 400 mV/g at $+25\text{C}$ to 400 mV/g +1.2% = 404.8 mV/g.

SPECIFICATIONS SUBJECT TO CHANGE WITHOUT NOTICE

Silicon Designs, Inc. • 13905 NE 128th Street, Kirkland WA 98034 • Phone: 425-391-8329 • Fax: 425-391-0446

SAMPLE OF INCLUDED TEST REPORT

Every 1522 accelerometer is accompanied by a test report featuring the measured bias, scale factor, bias and scale factor over temperature, linearity, output, and frequency and phase response.

ACCELEROMETER TEST REPORT

Model 1522L-100	Supply Current (I _{dd}) 5.32 mA	Part # 172-00226-04
Full Scale 100 g	Scale Factor (Sensitivity) 40.00 mV/G	Doc. Rev. -
Cal. Date 05/15/19	S.F. Temp. Coeff. -36 PPM/°C	Mfg. Lot # 19A079E
Serial # 673650	0 G Bias (Offset) 0 mV	Operator SS
	0 G Bias Temp. Coeff. -12 PPM of span/°C	Op. Number 120

Linearity and Output*

The graph shows a linear relationship between Applied G Level and Differential Out (V). The error (% of span) remains very close to 0% across the range from -60g to 60g.

Frequency and Phase Response**

The graph shows Gain (dB) and Phase (deg) vs Frequency (Hz). Gain is flat at 0 dB until approximately 1000 Hz, then drops to -3 dB at 5400 Hz. Phase is flat at 0 degrees until approximately 1000 Hz, then drops to -360 degrees at 5400 Hz.

Freq. (Hz)**	20	50	100	190	370	720	1400	1960	2320	2750	3250	3850	4560	5400
dB Out - X	0.01	0.01	0.00	-0.01	-0.05	-0.17	-0.62	-1.23	-1.77	-2.58	-3.84	-7.17	-13.14	-21.24
Phase (deg)	-0.8	-1.9	-3.7	-6.9	-13.5	-26.2	-51.0	-71.4	-84.5	-100.0	-117.3	-133.6	-146.7	-157.2

* Peak Acceleration Traceable to SDI Shaker System Test Interface M90257
** Reference Frequency is 100 Hz

Final Status
Pass

www.silicondesigns.com

sales@silicondesigns.com

+1-425-391-8329

SPECIFICATIONS SUBJECT TO CHANGE WITHOUT NOTICE

OPERATION

The model 1522 sensitive axis is perpendicular to the bottom of the package, with positive acceleration resulting from a positive force pushing on the bottom of the package. The seismic center is located on a centerline through the dual sense elements and halfway between them.

The Model 1522 produces a differential +/-4 volts output voltage, the value of which varies with acceleration as shown in the figure. The seismic center is located on a centerline through the dual sense elements halfway between them. Any errors due to rotation about this point are effectively cancelled by the internal electronics.

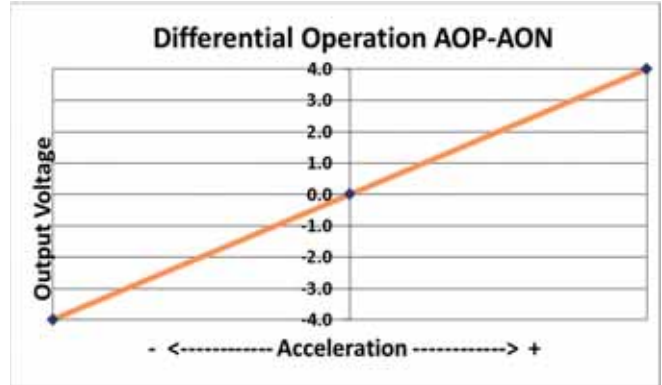

Two reference voltages, +5.0 and +2.5 volts (nominal), are required; scale factor is ratiometric to the +5.0 volt reference voltage relative to GND, and both outputs at zero acceleration are nominally the same as the +2.5 volt input.

SIGNAL DESCRIPTIONS

V_{DD} and GND (power): Pins (14) and (19) respectively. Power (+5 Volts DC) and ground.

AOP and AON (output): Pins 12 and 16 respectively. Analog output voltages proportional to acceleration. The AOP voltage increases (AON decreases) with positive acceleration; at zero acceleration both outputs are nominally equal to the +2.5 volt reference. The device experiences positive (+1g) acceleration with its lid facing up in the earth's gravitational field. Use of differential mode is strongly recommended for both lowest noise and highest accuracy operation. Voltages can be measured ratio-metrically to VR for good repeatability without requiring a separate precision reference voltage for an A/D.

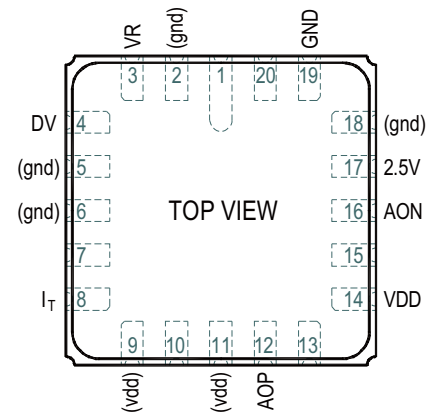

DV (input): Pin 4. Deflection Voltage. Connect to the 2.5 Volt pin for best repeatability. A test input that applies an electrostatic force to the sense element, simulating a positive acceleration. The nominal voltage at this pin is $\frac{1}{2} V_{DD}$. DV voltages higher than required to bring the output to positive full scale may cause device damage to 2g, 5g, and 10g devices.

VR (input): Pin 3. Voltage Reference. Tie to a good reference (not directly to V_{DD}) for best scale factor repeatability. A 0.1μF bypass capacitor is recommended at this pin. The current is less than 100 μA.

2.5 Volt (input): Pin 17. Sets internal and output common mode value. Tie to a resistive voltage divider from +5 volts. A 0.1μF bypass capacitor is recommended at this pin. The current is less than 50 μA.

I_T (output): Pin 8. Temperature dependent current source. May be tied to V_{DD} or left disconnected if not used.

Special Use Pins: Pins 9 and 11 should be tied to V_{DD}, Pins 2, 5, 6, and 18 to GND.

*** Pins 1, 7, 10, 13, 15, and 20 are reserved for future use and should remain unused ***

OPTIONAL INTERNAL TEMPERATURE SENSING

The model 1522 accelerometer contains a temperature dependent current source that is output on pin 8. This signal is useful for measuring the internal temperature of the accelerometer so that any previously characterized bias and scale factor temperature dependence, for a particular accelerometer, can be corrected.

The nominal output current at 25°C is ≈ 500 (± 200) μA and the nominal sensitivity is 1.5 (± 0.5) $\mu\text{A}/^\circ\text{C}$. Fluctuations in V_{DD} & V_{R} have little effect on the temperature reading. A reduction of 0.10 V to both V_{DD} & V_{R} will reduce the current about 1 μA , which corresponds to less than a 1°C change in reading. With a single resistor $R_{\text{T}} = 2\text{K}$ between I_{T} (pin 8) and GND the output voltage V_{T} will vary between +0.76 and +1.3 volts from -55 to +125°C, which equates to a sensitivity of $\approx +3$ mV/ $^\circ\text{C}$.

If a greater voltage change versus temperature or lower signal source impedance is needed, add the amplifier as shown on the right side in Figure 2. With offset voltage $V_{\text{OFF}} = -5\text{V}$, gain resistor $R_{\text{G}} = 15.0\text{K}$ and offset resistor $R_{\text{OFF}} = 7.32\text{K}$, the output voltage V_{T} will vary between +4.5 and +0.5 Volts from -55 to +125°C, which equates to a sensitivity of ≈ -29 mV/ $^\circ\text{C}$.

Figure 3 shows the voltage compliance of the temperature dependent current source (I_{T}) at room temperature. The voltage at pin 8 must be kept in the 0 to +3V range in order to achieve proper temperature readings.

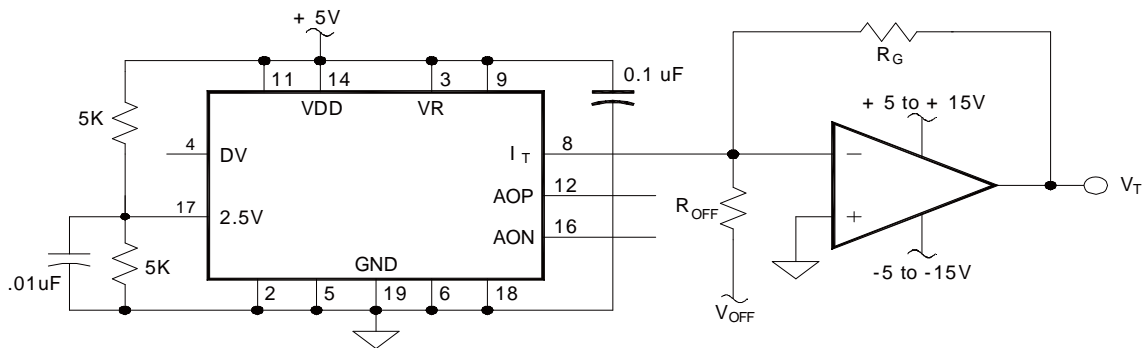
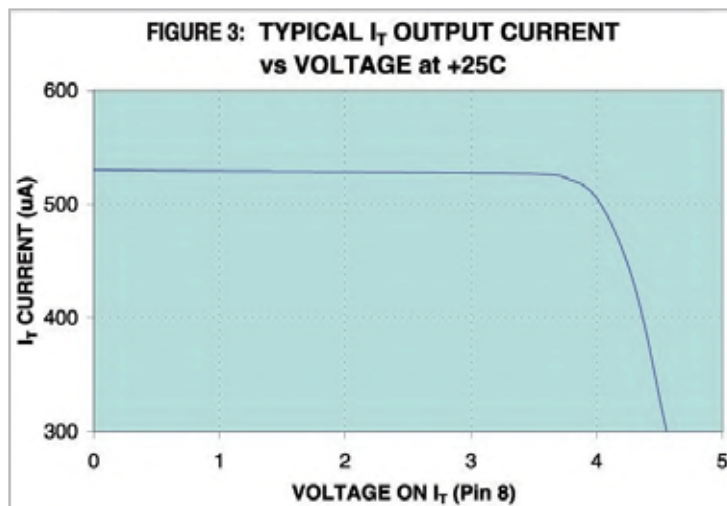

Figure 2



SPECIFICATIONS SUBJECT TO CHANGE WITHOUT NOTICE

PACKAGE DIMENSIONS

1. *Dimensions "M," "T," and "U" locate sensing element's center of mass.
2. Lid is electrically tied to terminal 19 (GND).
3. Controlling dimension: Inch.
4. Terminals are plated with 60 micro inches min gold over 80 micro inches min nickel. This plating specification does not apply to the Pin-1 identifier mark on the bottom of the J-lead package version.
5. Package: 90% min alumina (black), lid: solder sealed kovar.

Dim	Inches		Millimeters	
	Min	Max	Min	Max
A	0.342	0.358	8.69	9.09
C	0.055 TYP		1.40 TYP	
D	0.095	0.115	2.41	2.92
E	0.085 TYP		2.16 TYP	
F	0.050 BSC		1.27 BSC	
G	0.025 TYP		0.64 TYP	
H	0.050 TYP		1.27 TYP	
J	0.004 x 45°		0.10 x 45°	
K	0.010 R TYP		0.25 R TYP	
L	0.016 TYP		0.41 TYP	
*M	0.066 TYP		1.68 TYP	
*T	0.085 TYP		2.16 TYP	
*U	0.175 TYP		4.45 TYP	

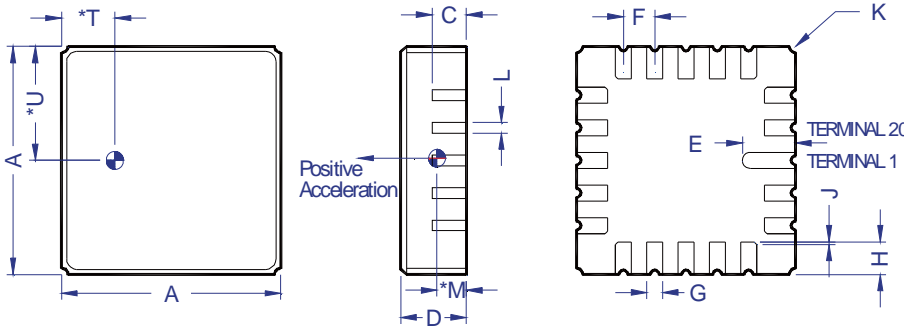

RECOMMENDED CONNECTIONS

DEFLECTION VOLTAGE (DV) TEST INPUT: This test input applies an electrostatic force to the sense element, simulating a positive acceleration of up to +10g. It has a nominal input impedance of 32 kΩ and a nominal open circuit voltage of ½ V_{DD}. For best accuracy during normal operation, this input should be left unconnected or connected to a voltage source equal to ½ of the V_{DD} supply.

The change in differential output voltage (AOP - AON) is proportional to the square of the difference between the voltage applied to the DV input (V_{DV}) and ½ V_{DD}. Only positive shifts in the output voltage may be generated by applying voltage to the DV input. When voltage is applied to the DV input on 2g, 5g, or 10g devices, it should be applied gradually to avoid damage. The application of DV voltages greater than required to bring the output to positive full scale may cause device damage. The proportionality constant (*k*) varies for each device and is not characterized.

ESD and LATCH-UP CONSIDERATIONS: The model 1522 accelerometer is a CMOS device subject to damage from large electrostatic discharges. Diode protection is provided on the inputs and outputs, and it is not easily damaged, but care should be exercised during handling. However, individuals and tools should be grounded before coming in contact with the device. Although the 1522 is resistant to latch-up, inserting a 1522 into or removing it from a powered socket may cause damage.

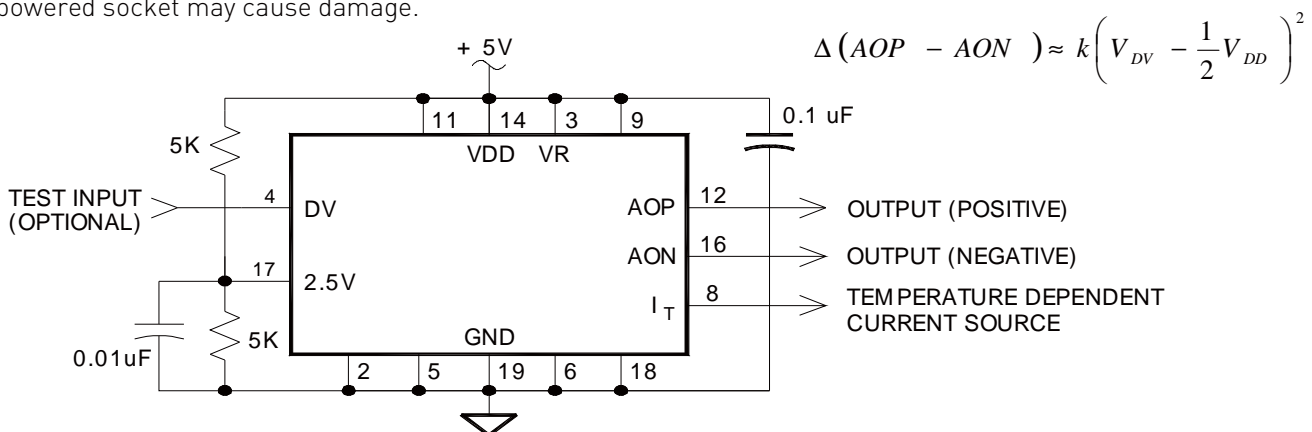

SPECIFICATIONS SUBJECT TO CHANGE WITHOUT NOTICE

SOLDERING RECOMMENDATIONS

RoHS Compliance: The model 1522 does not contain elemental lead and is RoHS compliant.

Soldering: Solder reflow should not exceed 239°C, exceeding this temperature may result in permanent damage.

Pre-Tinning of Accelerometer Leads is Recommended: To prevent gold migration embrittlement of the solder joints, it is best to pre-tin the accelerometer leads.

LCC Solder Contact Plating Information: The plating composition and thickness for the solder pads and castellations on the “L” suffix (LCC) package are 60 to 225 micro-inches thick of gold (Au) over 80 to 350 micro-inches thick of nickel (Ni) over a minimum of 5 micro-inches thick of moly-manganese or tungsten refractory material.

Recommended Solder Pad Pattern: The recommended solder pad size and shape is shown in the diagram and table below. These dimensions are recommendations only and may or may not be optimum for your particular soldering process.

Do not use ultrasonic cleaners. Ultrasonic cleaning may break internal wire bonds and will void the warranty.

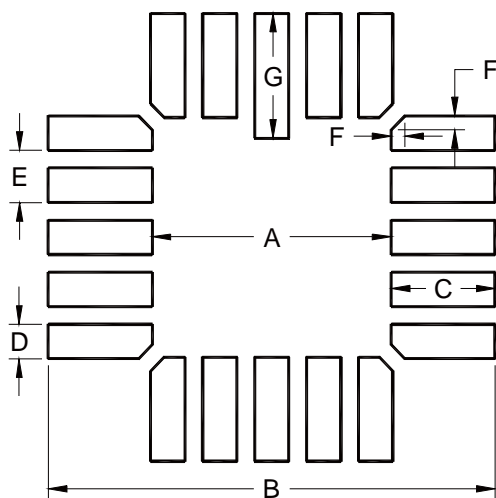

DIM	Inch	mm
A	.230	5.84
B	.430	10.92
C	.100	2.54
D	.033	0.84
E	.050	1.27
F	.013	0.33
G	.120	3.05

COMPANION ACCESSORY

The Model EB-L Test Sets provide a convenient means of testing and evaluating SDI Model 1522 surface mount accelerometers. The zero-insertion-force socket is pre-fitted to the board, which includes set jumpers for advanced features of SDI accelerometers. A 10-pin connector and ribbon cable provide connections to the user’s test equipment. The EB-L Test Sets and SDI Surface Mount Accelerometers are each sold separately.



SPECIFICATIONS SUBJECT TO CHANGE WITHOUT NOTICE

TEST REPORT EXAMPLES: LINEARITY, PHASE & FREQUENCY RESPONSE BY G-LEVEL

The included 1522-TST test reports provide additional information about the linearity, output, phase, and frequency response as tested for each individual unit. The following are examples of the graphical data supplied on test reports, by G-level.

NOTE: Frequency response on test reports is documented by simulating frequency response with the DV pin. This will indicate lower values than the actual performance once soldered or otherwise permanently installed upon a board.

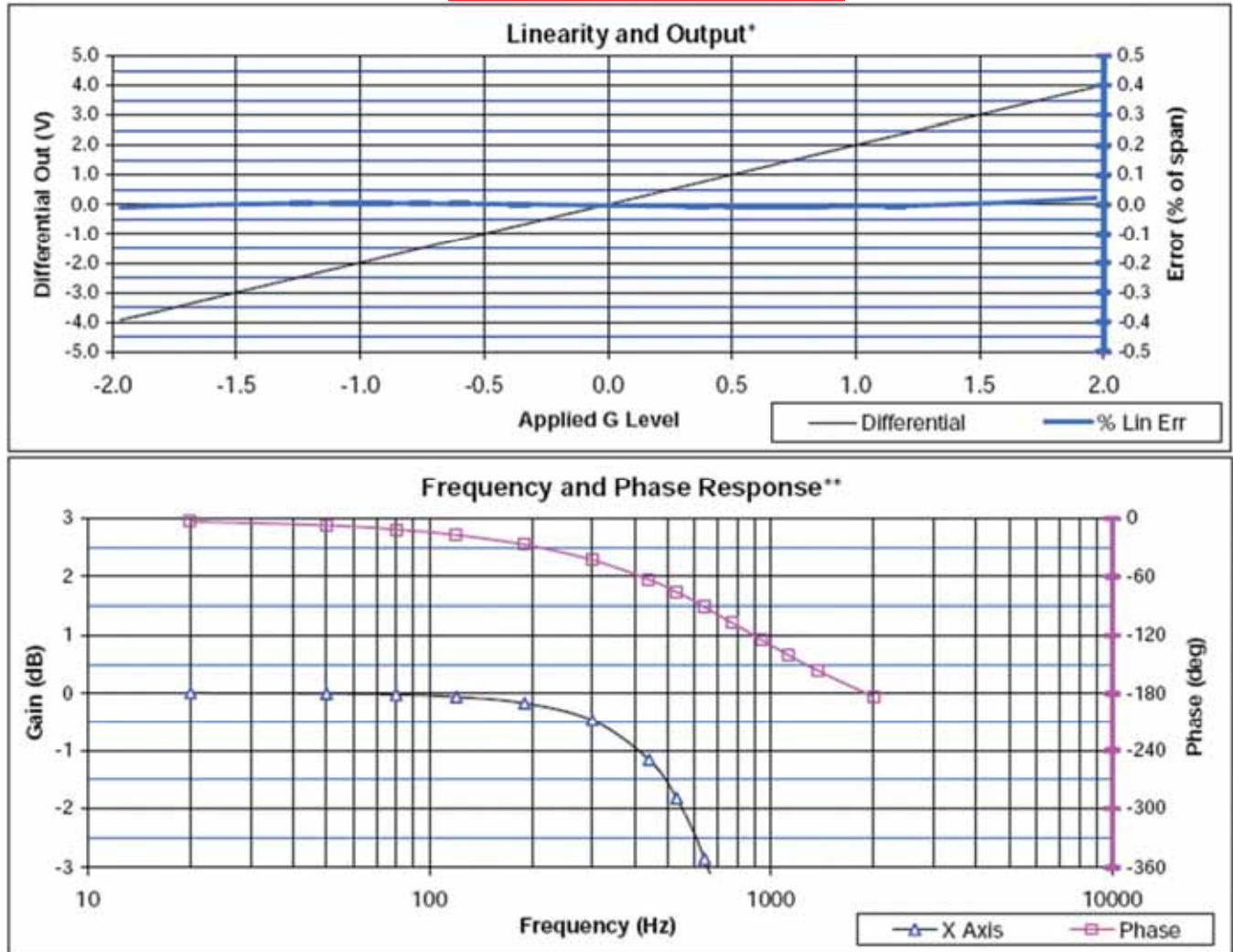
EXAMPLE 2G: 1522L-002

EXAMPLE 5G: 1522L-005

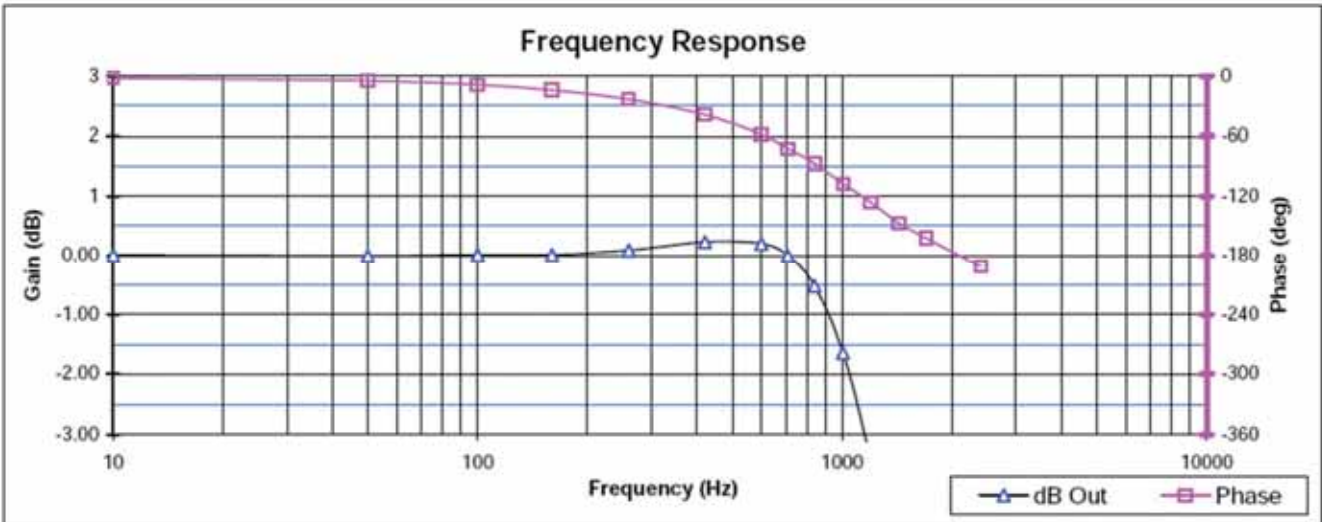
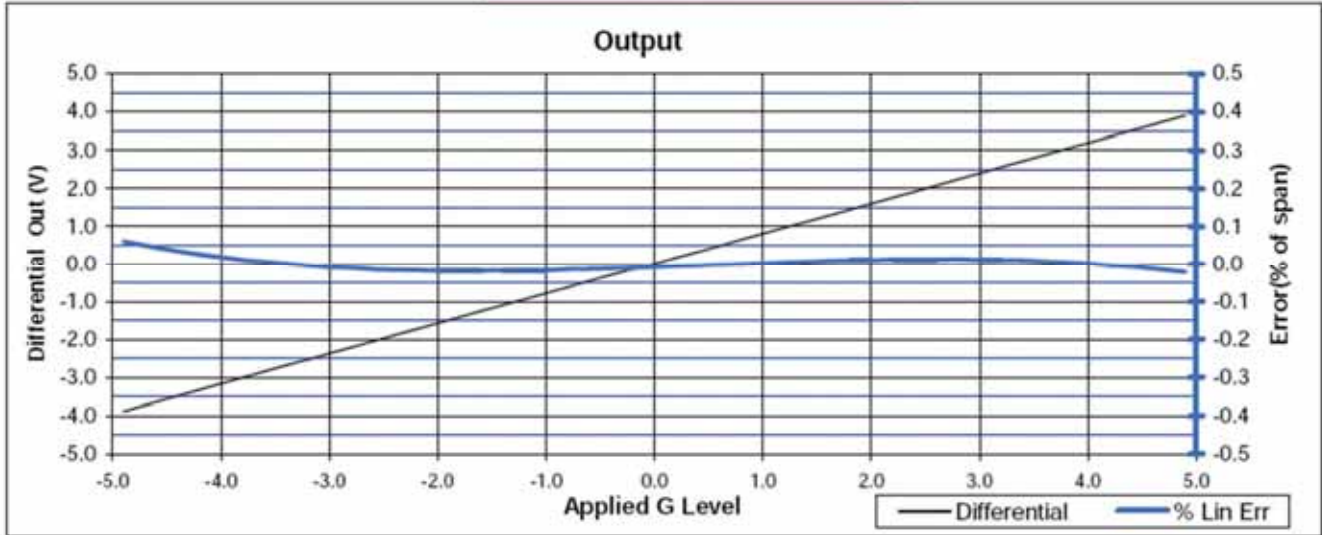

SPECIFICATIONS SUBJECT TO CHANGE WITHOUT NOTICE

EXAMPLE 10G: 1522L-010

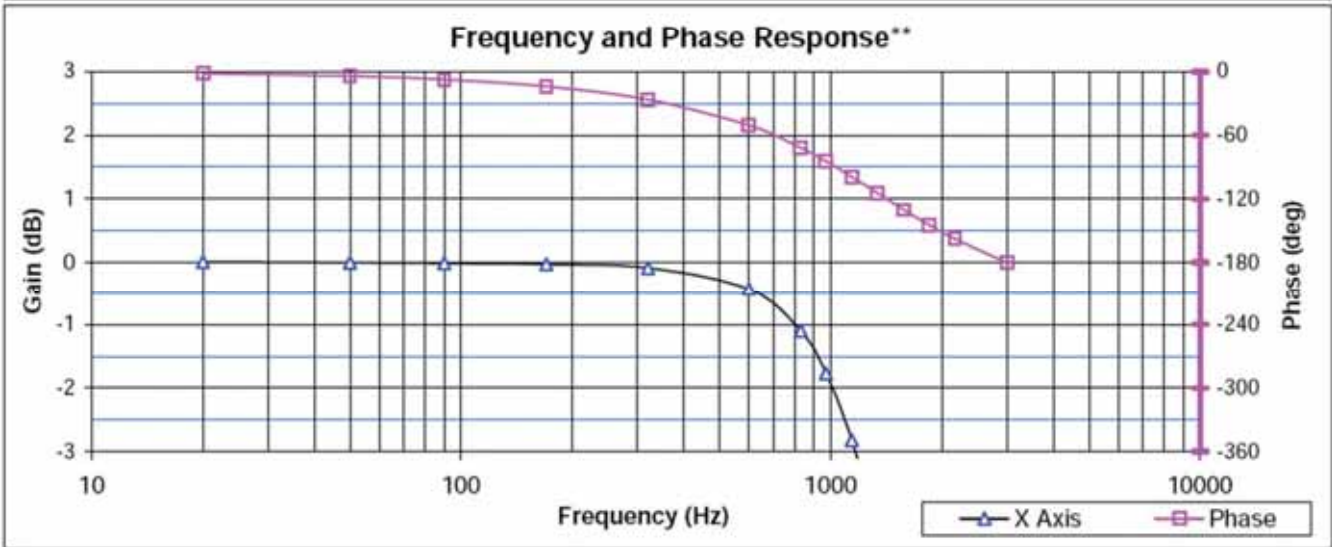
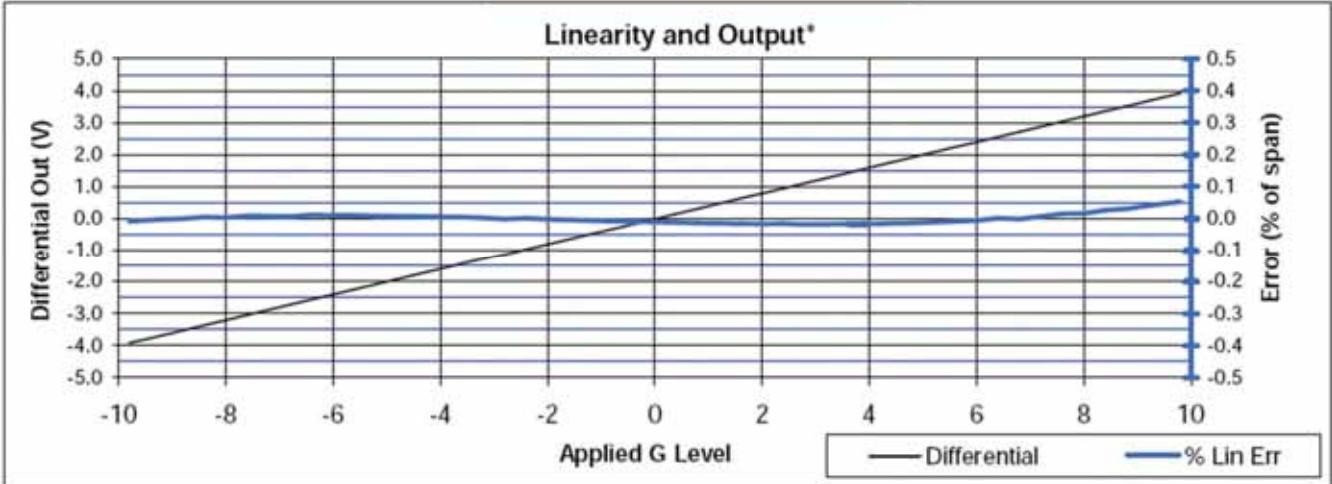

SPECIFICATIONS SUBJECT TO CHANGE WITHOUT NOTICE

EXAMPLE 25G: 1522L-025

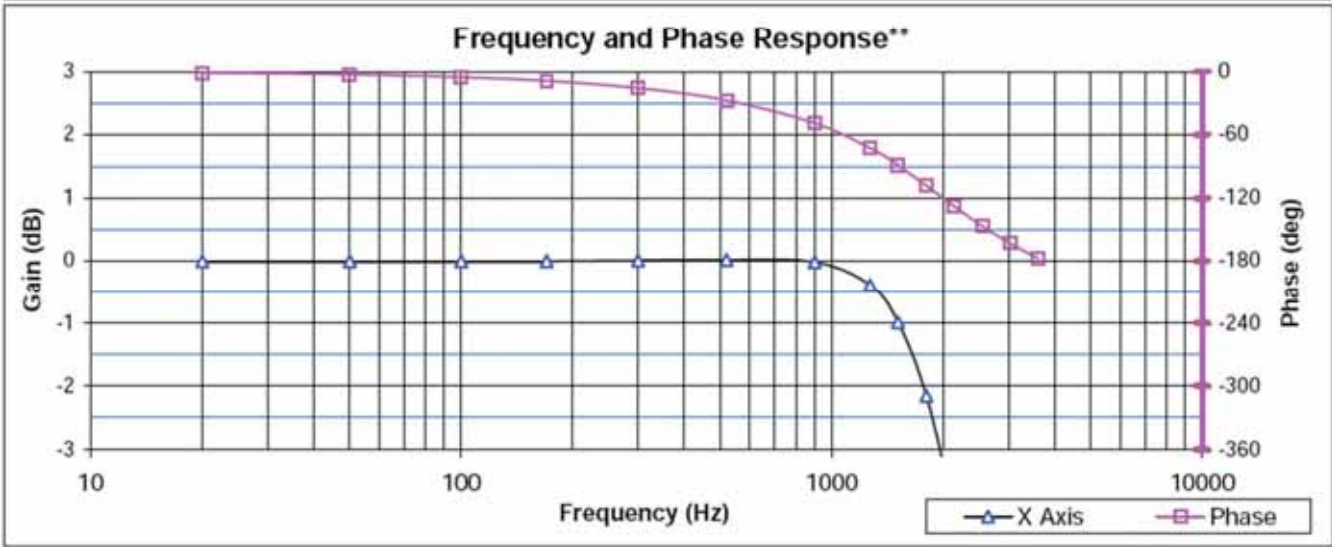
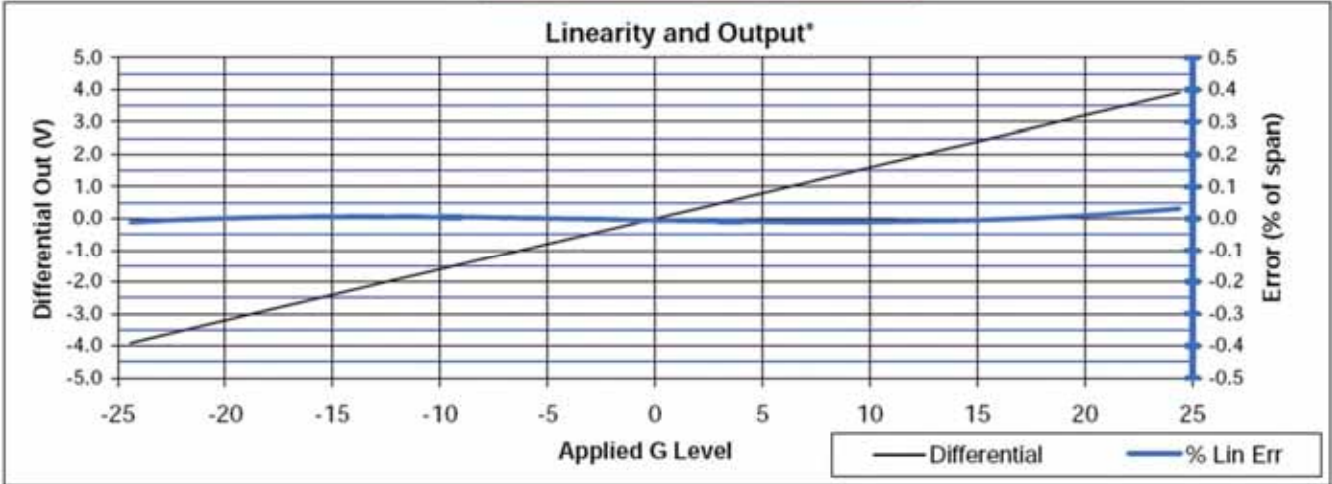

SPECIFICATIONS SUBJECT TO CHANGE WITHOUT NOTICE

EXAMPLE 50G: 1522L-050

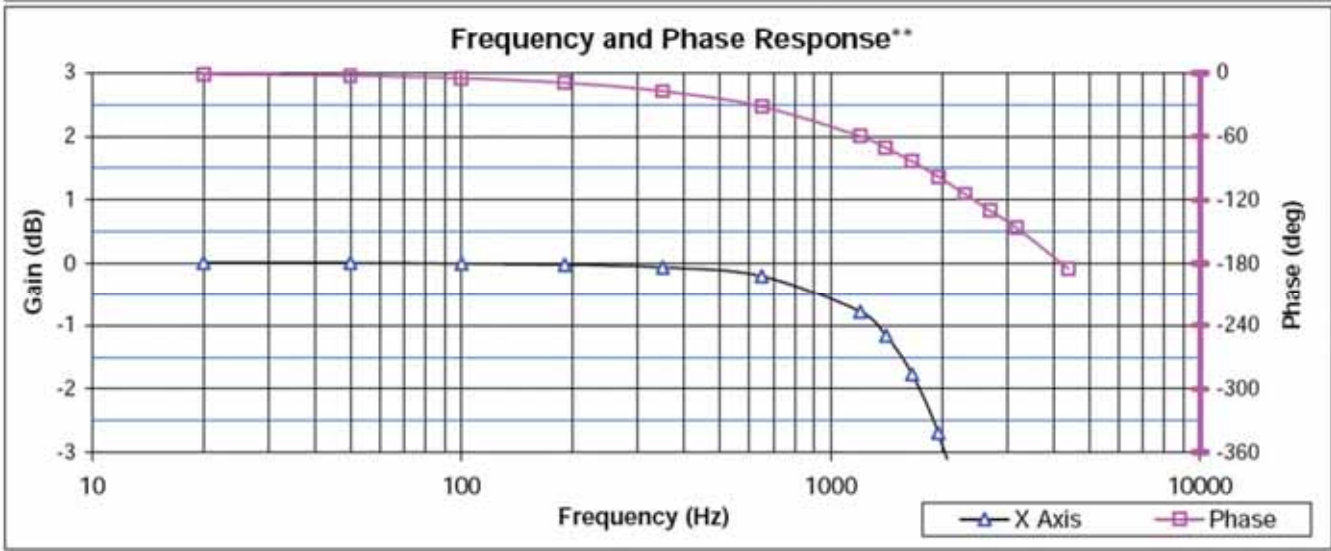
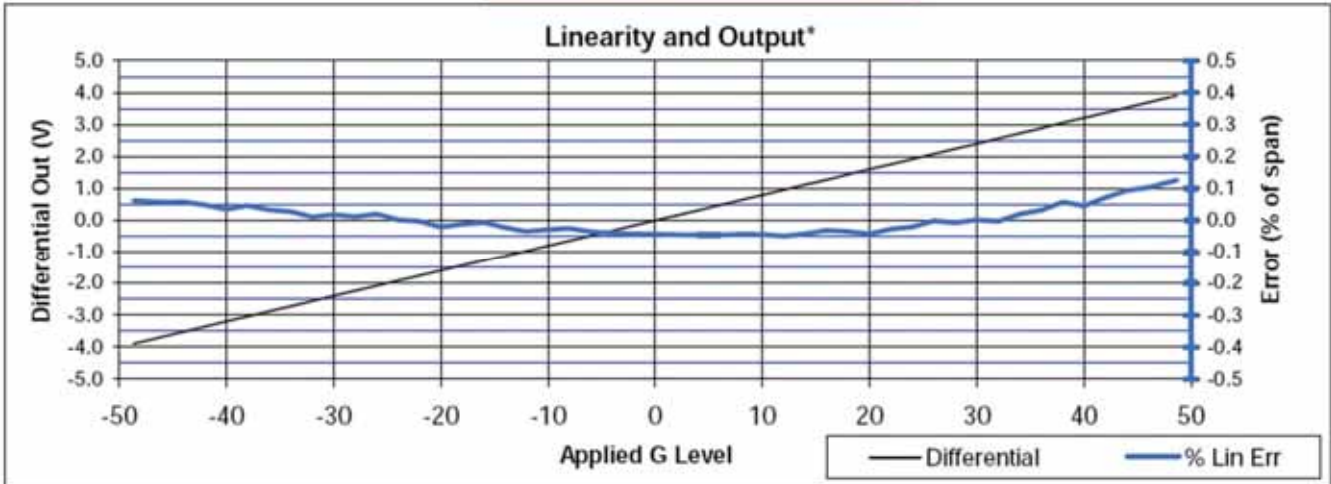

SPECIFICATIONS SUBJECT TO CHANGE WITHOUT NOTICE

EXAMPLE 100G: 1522L-100

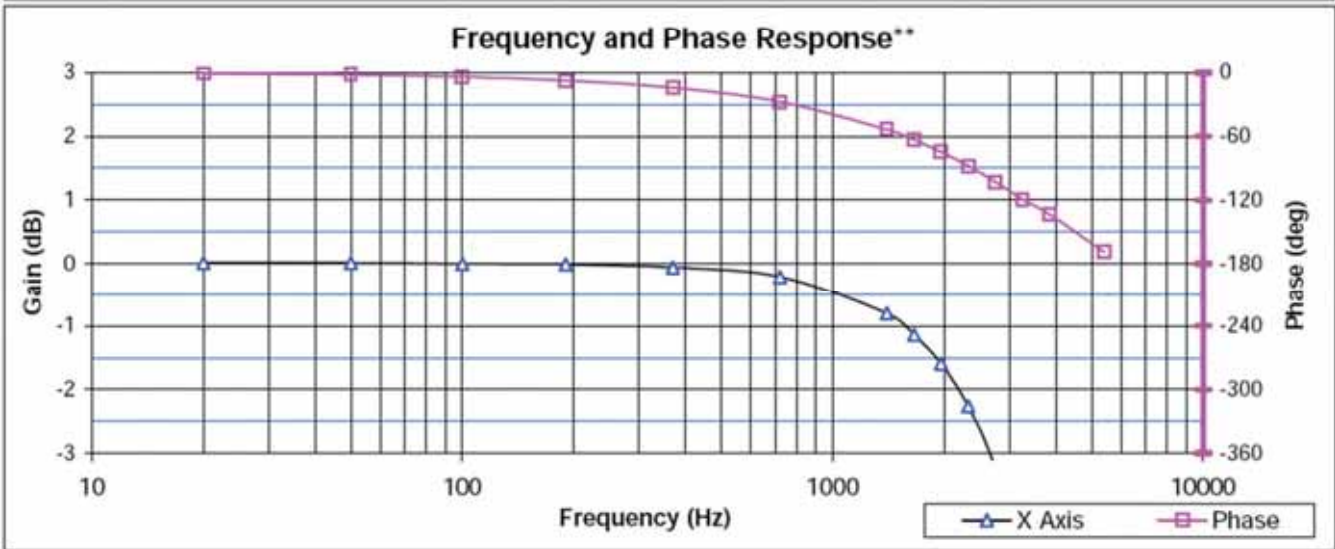
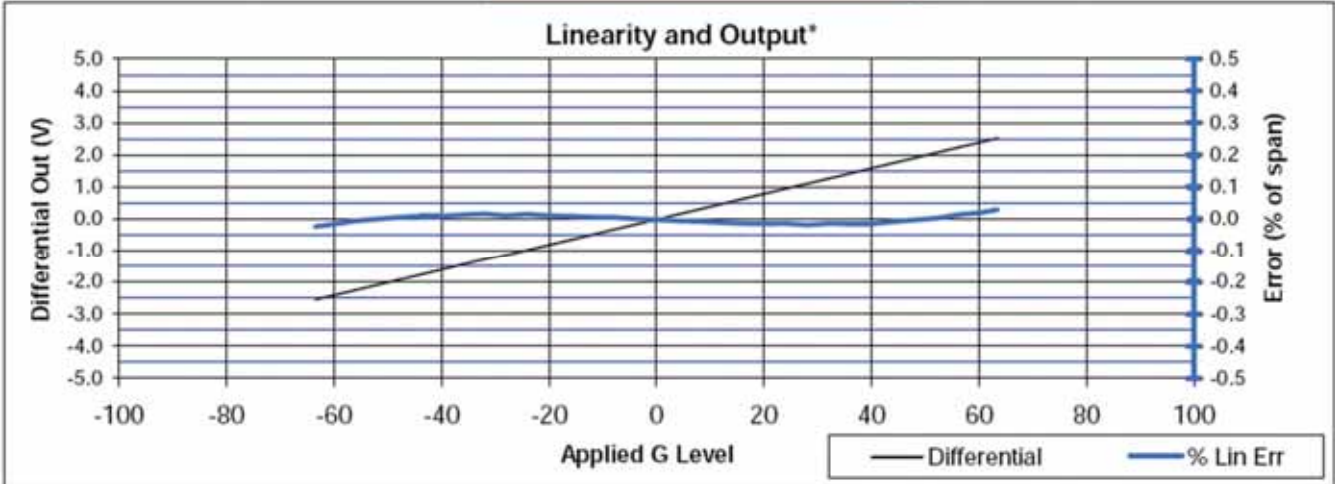

SPECIFICATIONS SUBJECT TO CHANGE WITHOUT NOTICE

EXAMPLE 200G: 1522L-200

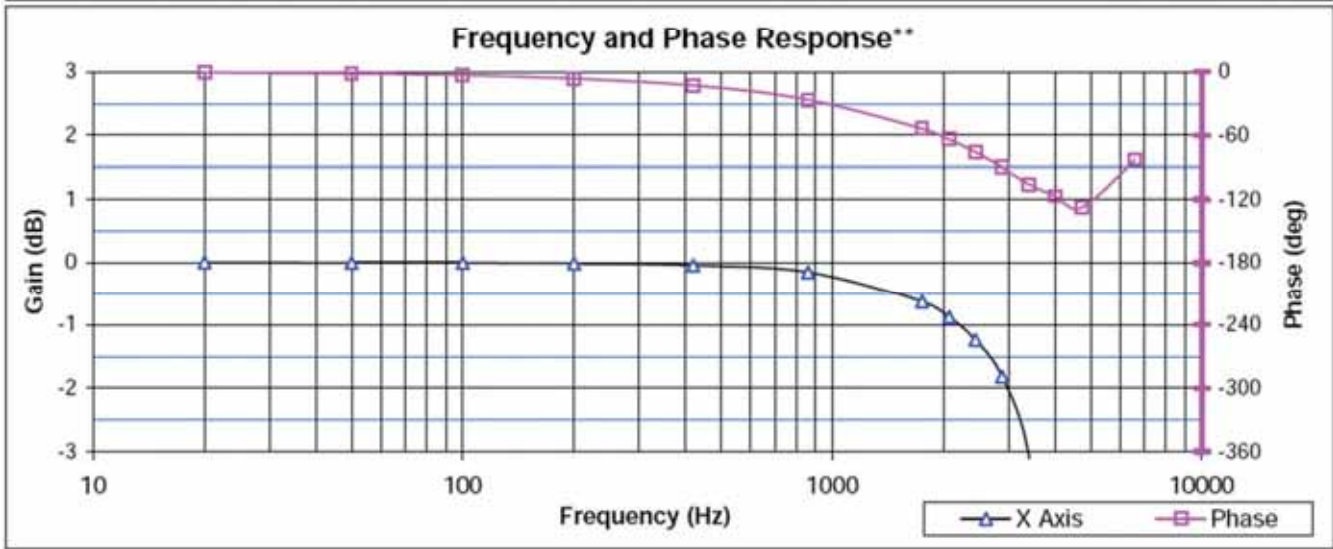
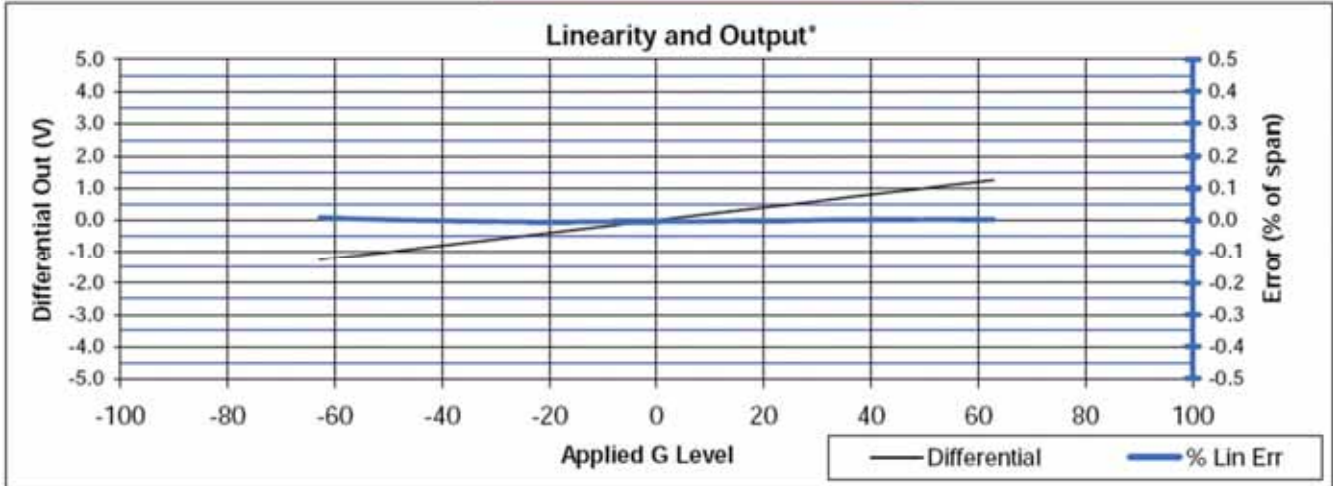

SPECIFICATIONS SUBJECT TO CHANGE WITHOUT NOTICE

EXAMPLE 400G: 1522L-400

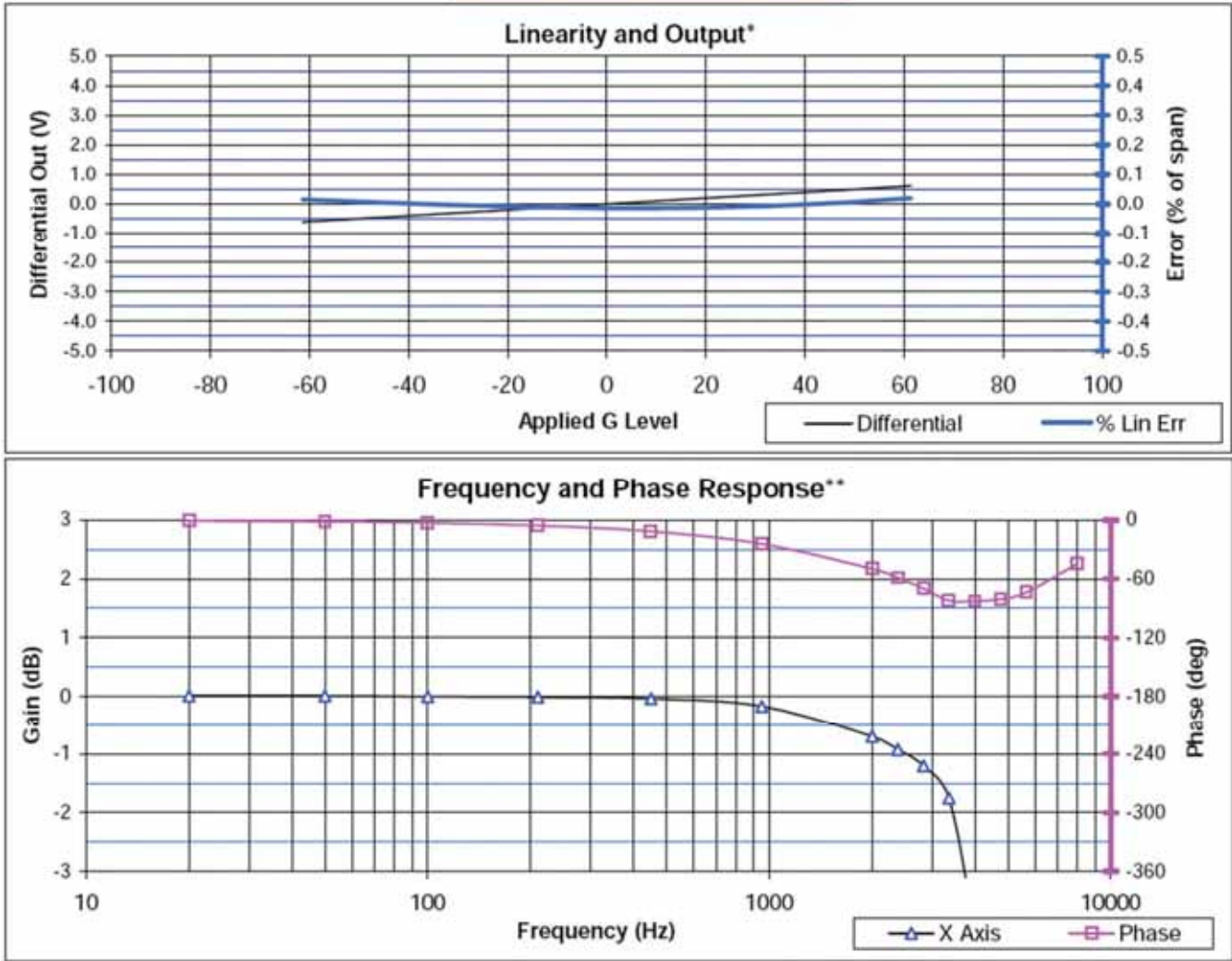

株式会社 クローネ

■ カタログに掲載してある製品の色は印刷インキの関係上、実際とは異なる場合があります。
 ■ 製品のデザイン、仕様等などは、予告なく変更する場合があります。

本 社：〒124-0023 東京都葛飾区東新小岩3丁目9番6号 TEL: (03) 3695-5431 / FAX: (03) 3695-5698
 大阪支店：〒530-0054 大阪市北区南森町2-2-9(南森町八千代ビル7F) TEL: (06) 6361-4831 / FAX: (06) 6361-9360
 e-mail: sales-tokyo@krone.co.jp URL: https://www.krone.co.jp

SPECIFICATIONS SUBJECT TO CHANGE WITHOUT NOTICE