

- Small Bias and SF Temperature Coefficients
- Excellent Long Term In-Run Bias Stability
- Calibrated Internal Temperature Sensor
- $\pm 4.0$  mA Full Scale Current Output
- $\pm 9$  to  $\pm 16$  Volt DC, 16 mA Maximum

- -55 to +125°C Operation
- Two Built-In Self Tests
- Durable to 5000+g Mechanical Shocks
- Hermetically Sealed MEMS Accelerometer
- Serialized for Traceability & RoHS Compliant

Pin and Form  
Factor Compatible  
with Industry-  
Standard Quartz  
Accelerometers

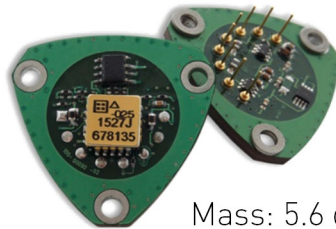

Mass: 5.6 grams

### AVAILABLE G-RANGES

FULL SCALE ACCELERATION	MODEL NUMBER
$\pm 10$ g	2227-010
$\pm 25$ g	2227-025
$\pm 50$ g	2227-050

## DESCRIPTION

The Model 2227 module combines a high-temperature, open printed circuit board (PCB) specifically designed to give the high stability required for inertial applications and SDI's Model 1527 Tactical-Grade Inertial Navigation MEMS Accelerometer. The 2227 is a low-mass, low-power module, electrically and mechanically compatible with fixtures and equipment designed for industry-standard quartz accelerometers and intended for use in inertial and tilt applications requiring zero to medium frequency response excellent long-term bias and scale factor repeatability, and low noise.

The SDI Model 1527 MEMS Accelerometer combines two patented capacitive silicon sense elements and a precision, custom CMOS integrated circuit in a hermetically sealed LCC package. The differential output voltage of the MEMS accelerometer is converted on the PCB into a current proportional to the applied acceleration. Thermal calibration parameters can be provided for the 2227 module to achieve high performance with user real-time temperature compensation and modeling software.

## ZERO (DC) TO MEDIUM FREQUENCY APPLICATIONS



**INERTIAL**



**NAVIGATION**



**INSTRUMENTATION**



**OEM**



**ROBOTICS**



**AEROSPACE**

## PERFORMANCE \*

PERFORMANCE	INPUT RANGE:	$\pm 10G$	$\pm 25G$	$\pm 50G$	UNITS
Bias, Typical <sup>1</sup>		$\pm 0.2$	$\pm 0.2$	$\pm 0.2$	% of FS
Bias Long-Term Repeatability (1 $\sigma$ ) <sup>3</sup>		1.00	1.50	3.0	mg
Bias Temperature Coefficient, Typical <sup>1</sup>		5	5	5	PPM/°C of FS
In Run Bias Stability at +1g, 2-40,000 sec. (AV Min) Typical		12	30	60	$\mu g$
Scale Factor Sensitivity, Nominal, +/- 0.5%		400	160	80	$\mu A/g$
Scale Factor Long Term Repeatability (1 $\sigma$ ) <sup>2,3</sup>		300	300	300	PPM
Scale Factor Temperature Coefficient, Typical <sup>1</sup>		12	10	10	PPM/°C
Input Axis Misalignment, Typical <sup>2</sup>		5	5	5	mrad
Vibration Rectification, Typical <sup>2</sup>	10-50 Hz, Random	TBD	30	TBD	$\mu g/g^2$ rms
	50-200 Hz, Random		100		
Output White Noise, Typical		18	25	50	$\mu g/\sqrt{Hz}$ rms
Velocity Random Walk, Typical		0.007	0.012	0.025	m/s $\sqrt{Hr}$
RMS Model Residual (+/- 1g), Typical <sup>1,4</sup>		15	12	12	PPM of FS
Frequency Response, DC to -3 dB, Nominal		0 - 600	0 - 1000	0 - 1400	Hz

\* SPECIFIED -55°C TO +85°C, Unless otherwise specified Vin = +/- 12 Volts, TC=25°C

SPECIFICATIONS SUBJECT TO CHANGE WITHOUT NOTICE

PERFORMANCE * all models	MIN	TYP	MAX	Units
Temperature Sensor Sensitivity, Nominal +/- 0.3°C		1.0		uA/°C
Temperature Sensor Calibration Error		0.5		°C
Accelerometer Non-Linearity		0.1	0.2	% of FS
Turn-On Time to < 150 ppm of Output Value		0.5		mSec
Operating Voltage for Full Scale Acceleration Input	+/-9		+/-16	Volts
Quiescent Operating Current at +/-12 Volts		10	12	mA
Operating Temperature	-55		+125	°C
Storage Temperature	-55		+125	°C
Applied Voltage on Digital Self-Test Pins 2 and 7	-0.5		5.5	Volts
Peak Continuous Vibration (Operating and Non-operating)			200	% FS
Mechanical Shock (0.1 ms)			5000	g - peak
Mass		5.6		grams
PCB Material: Rigid Polyimide, CTE		16		ppm/°C

**Note 1:** Tested over the range -55°C to +85°C

**Note 2:** Subject to Change.

**Note 3:** Long-term aging tests include: Power Cycle 100 x; Shock 500g all axes; Storage at -40°C and +100°C; Temperature Cycle 10x; -55 to 125C; Random Vibration, 10–1000Hz band, Peak 90% of FS.

**Note 4:** Recommended Model:

- Applied Acceleration =  $B_0 + B_1 * T + B_2 * T^2 + B_3 * T^3 + I_{out} * (C_0 + C_1 * T + C_2 * T^2)$ , where parameters are the least squares fit, with  $T = (\text{temperature sensor current} - 273C - 25C)$  and  $I_{out}$  is the Output Current.
- The 2227 uses a temperature sensor thermally coupled to the MEMS accelerometer to measure its temperature. The nominal current output is calibrated and trimmed to be nominally the same in uA as the temperature in degrees Kelvin. The value of the current from the temperature sensor is used by SDI to determine the thermal calibration coefficients. The calibration coefficients used in a system should be adjusted to reflect the differences in current measurement calibration after the accelerometer has been installed in a system.

**Note 5:** All specifications are subject to change without notice.

**\* NOTICE:** Stresses greater than those listed above may cause permanent damage to the device. These are maximum stress ratings only. Functional operation of the device at or above these conditions is not implied. Exposure to absolute maximum rating conditions for extended periods may affect device reliability and lifespan.

## OPERATION

The model 2227 input axis is perpendicular to the PCB. The seismic center is located at the center of the PCB inside the LCC accelerometer, approximately 0.110 inches (2.75 mm) above the top of the PCB, the reference surface for the 2227.

The Model 2227 generates an output current, the value of which varies with acceleration as shown in the adjacent figure.

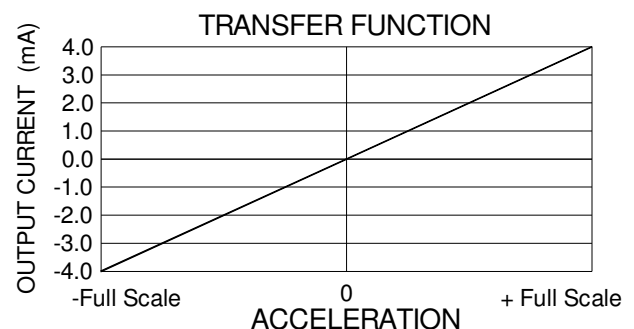

SPECIFICATIONS SUBJECT TO CHANGE WITHOUT NOTICE

## SIGNAL DESCRIPTIONS

**Pin 1 – Measured Acceleration (Output):** The value of the applied acceleration is measured by a current from this pin to Ground (pin 8). An external sensing resistor is normally used to convert this current into a voltage.

**Pin 2 – CapTest (Digital Input):** A digital-logic True (+5 volts) applied to this pin causes the accelerometer to disconnect the sense element and substitute a fixed capacitor array that is measured by the CMOS ASIC. The accelerometer is insensitive to applied acceleration while this pin is True. An internal 5K resistor is connected from this pin to Ground. If not used, this pin can be left open or connected to Ground.

**Pin 3 – Negative Supply Voltage (Input):** A voltage of -9 to -18 volts is required.

**Pin 4 – Positive Supply Voltage (Input):** A voltage of +9 to +18 volts is required.

**Pin 5 – Internal Reference Voltage (Output):** This pin reflects the voltage from an internal voltage reference that supplies VDD and VR to the LCC accelerometer. This pin is isolated from the reference by a 1K ohm resistor. For automatic compensation for voltage reference aging, the voltage on this pin, relative to the Ground terminal, can be amplified by a high input impedance op-amp and its output used as the reference for an A/D converter. Alternatively, the voltage can also be measured by an A/D, and the compensation done in software. If not used, this pin should be left open.

**Pin 6 – Temperature (Output):** This pin has current output to Ground proportional to the LCC temperature in degrees Kelvin. The nominal value of temperature sensor scale factor is trimmed to 1.0uA/deg K. If not used, this pin can be left open.

**Pin 7 – Sense Element Test (Digital Input):** A digital-logic True (+5 volts) applied to this pin causes the DV pin of the LCC to be connected to the internal reference voltage (VR), applying an additional positive electrostatic force on the sense element; the sense element responds by deflecting in a positive direction, producing a positive-going increase in the accelerometer output. The accelerometer continues to sense and measure applied acceleration plus this additional simulated acceleration while this pin is active. An internal 10K resistor is connected from this pin to Ground. If not used, this pin can be left open or connected to Ground.

**Pin 8 – Ground (Input and Output):** This pin is the power return for the positive and negative supply voltages. It also is the signal return for the current measuring the applied acceleration.

## PACKAGE DIMENSIONS

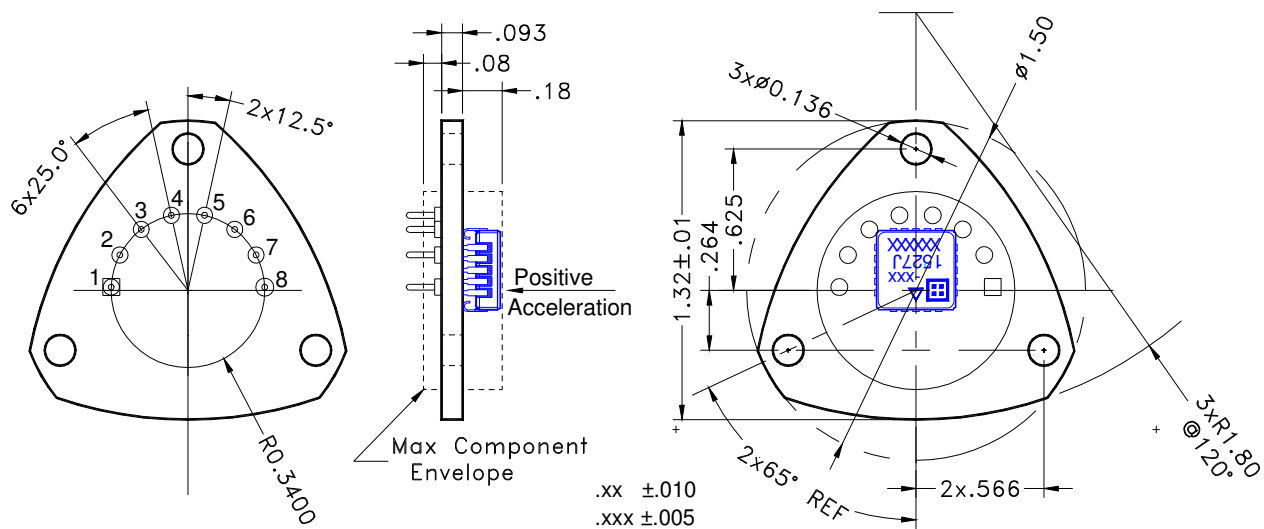

SPECIFICATIONS SUBJECT TO CHANGE WITHOUT NOTICE

## CONNECTIONS

### REQUIRED CONNECTIONS

The following connections are needed to operate the module:

- 1) Power: +9 Volts to +18 Volts to pin 4, -9 Volts to -18 Volts to pin 3 and Power Supply Ground to pin 8; and
- 2) Sensing Resistor: A sensing resistor between the output (pin 1) and Ground (pin 8). To utilize the full input range of the accelerometer, the sensing resistor with a value of 1K ohms or less should be used to convert this current into a voltage. If only a portion of the full-scale range is needed, a larger value resistor can be used, where the peak voltage across it is limited to +/- 4.0 volts over the input range.

Selection and connection of the sensing resistor is critical for accurate acceleration measurement. The measured bias and scale factor temperature coefficients (TCs) for the module will include the TC of the sensing resistor. If the sensing resistor is located where its temperature is changing, it is recommended that the sensing resistor have a TC is less than or equal to 2-3 ppm per degree C. Connections of the sensing resistor to the A/D measuring the accelerometer output should be at locations where the resistor and the circuit between the connections carries only the current that originates from the output (pin 1).

### OPTIONAL CONNECTIONS

Temperature measurement: The current output can be converted to a voltage using a 1.0K to 5.0K ohm resistor connected between pins 6 and Ground, (pin 8). The two self-test pins (pins 2 and 7) can be left unconnected, connected to Ground or connected to a digital source. The reference voltage on pin 5 and be used as described above or left unconnected.

Thermal Stress Relief: For a wide temperature range of operation, it is recommended that the PCB be attached to the mating surface in such a way that CTE differences can be accommodated by flexing of the mounts or sliding on the mating surface without significant stretching or compression of the PCB.

## SOLDERING/CLEANING

*Do NOT use ultrasonic cleaners. Ultrasonic cleaning may break internal wire bonds and void the warranty.*



株式会社 クローネ

■カタログに掲載してある製品の色は印刷インキの関係上、実際とは異なる場合があります。  
■製品のデザイン、仕様等などは、予告なく変更する場合があります。

本 社：〒124-0023 東京都葛飾区東新小岩3丁目9番6号 TEL: (03) 3695-5431 / FAX: (03) 3695-5698  
大阪支店：〒530-0054 大阪市北区南森町2-2-9(南森町八千代ビル7F) TEL: (06) 6361-4831 / FAX: (06) 6361-9360  
e-mail: sales-tokyo@krone.co.jp URL: <https://www.krone.co.jp>

SPECIFICATIONS SUBJECT TO CHANGE WITHOUT NOTICE