



# Protran® PR3420

Sludge Platform Submersible  
Depth/Level Pressure Transmitter



- Sludge Platform to raise sensor above sediment level
- Piezoresistive sensor technology for excellent stability and repeatability
- Robust stainless steel construction
- Pressure ranges available from 0-1 mWG
- High strength, moulded cable for protection against ingress
- ATEX/IECEx option available (includes M1 for mining applications)



Vers. 20/1/Eng



## Description

The PR3420 submersible depth and level transmitter has been designed for accurate level measurement where sediment is present. The integral sludge platform ensures that the sensing element is elevated above the sediment level.

The submersible range of pressure transmitters has been designed for the accurate measurement of the depth and level of liquids in many applications. Standard output signal is 4-20 mA, and electrical connection is via a high strength moulded cable with integral tube for trouble-free venting to the surface atmosphere.

An optional ATEX and IECEx approved version of this product is available for explosion protection for flammable gases (zone 0), dusts (zone 20) and mining areas (group I M1).

## Dimensions (in mm)

ELECTRICAL CONNECTION (mA)	
Red	+supply
Blue	4-20mA signal
Screen	to case

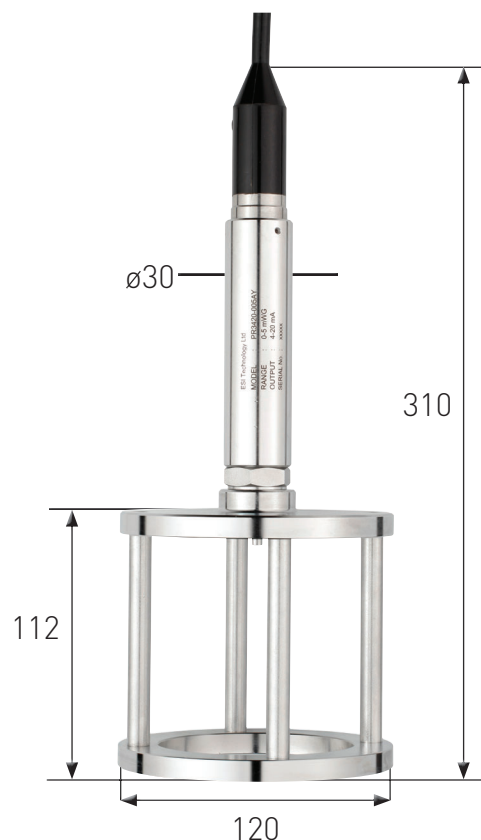
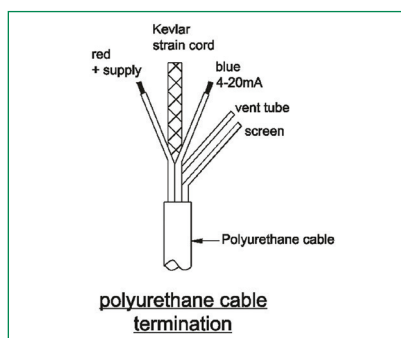



## Technical Data

Type:	PR3420	PR3421	PR3422
Sensor Technology:	Isolated Piezoresistive Silicon		
Output Signal:	4-20 mA (2 wire)	0-5 Vdc (4 wire)	0-10 Vdc (4 wire)
Supply Voltage:	13 -36 VDC	13 -30 VDC	13 -30 VDC
Pressure Reference:	Vented Gauge		
Protection of Supply Voltage:	Protected against supply voltage reversal up to 50 V		
Lightening Protection:	On Request		
Standard Pressure Ranges (mWG):	0-1 mWG; 0-10 mWG; 0-20 mWG; 0-50 mWG; 0-100 mWG; 0-250 mWG; 0-500 mWG (other options available)		
Standard Pressure Ranges (psi):	0-3 psi; 0-5 psi; 0-7.5 psi; 0-10 psi; 0-15 psi; 0-30 psi; 0-50 psi; 0-100 psi; 0-200 psi; 0-300 psi (other options available)		
Overpressure Safety:	2x all ranges		
Load Driving Capability:	4 – 20 mA: RL < [UB - 13 V] / 20 mA; (e.g. with supply voltage (UB) of 36V, max. load (RL) is 1150 Ω; 10 mV/V: n/a; 0 – 5 V: max. load RL > 5 KΩ; 0 – 10 V: max. load RL > 10 KΩ		
Accuracy NLHR:	≤ ±0.3 % of span BFSL		
Zero Offset and Span Tolerance:	±0.5% FS at room temperature		
Operating Ambient Temperature:	-20 °C – +60 °C (-4 °F to +140 °F)		
Operating Media Temperature:	Media must not freeze around the sensor		
Storage Temperature:	+5 °C to +40 °C (+41 °F to +104°F) Recommended Best Practice		
Temperature Effects:	±2.0% FS total error band for -20 °C – +60 °C. Typical thermal zero and span coefficients +/0.03%FS/°C		
ATEX/IECEx Approval Option (4-20mA version only):	Ex II 1 G Ex ia IIC T4 Ga (zone 0) Ex II 1 D Ex ia IIIC T135°C Da (zone 20) Ex I M 1 Ex ia I Ma (group 1 M1)		
ATEX/IECEx Safety Values:	Ui = 28 V Ii = 119 mA Pi = 0.65 W Li = 0.1 μH Ci = 62 nF Temperature Range = -20 °C to +70 °C Max. cable length = 105 m		
Electromagnetic Compatibility:	Emissions: EN61000-6-4; Immunity: EN61000-6-2; Certification: CE Marked		
Insulation Resistance:	> 100 MΩ @ 50 VDC		
Wetted Parts:	SAE 316L stainless steel housing and diaphragm, polyurethane cable and nitrile (NBR) o-ring seal; 303 stainless steel sludge platform		
Pressure Media:	All fluids compatible with SAE 316L stainless steel, 303 stainless steel, polyurethane and nitrile (NBR)		
Pressure Connection:	Sludge platform		
Electrical Connection:	Submersible black polyurethane cable moulded to housing. With integral screen, Kevlar strain cord and vent tube. Conductor size 7/0.20 mm (24 AWG), resistance 8.9 Ω / 100 m (x2)		
Net. Weight (Kg):	2.5 Kg		

## Order Matrix

Output	Wires	Type	Electrical Connector	Pressure Range	Process Connection	Cable Length
4-20mA	2	PR3420				
0-5 V	4	PR3421				
0-10 V	4	PR3422				
<b>Electrical Connection/ Option</b>						
No special option required			-			
ATEX/ IECEx certified			EX			
<b>Pressure Range in mWG (Metres Water Gauge)</b>						
0-1 mWG				0001		
0-5 mWG				0005		
0-10 mWG				0010		
0-50 mWG				0050		
0-100 mWG				0100		
0-250 mWG				0250		
0-500 mWG				0500		
<b>Process Connection</b>						
Sludge platform					AY	
<b>Cable Length</b>						
Cable length is specified by adding a 3 digit numeric code as a suffix to the part number. e.g. -010 = 10 metres. (Max cable length 500 metres)						xxx

**Order Number Example** PR3420-0010AY-010

For options not listed please contact the sales team



株式会社 クローネ

- カタログに掲載してある製品の色は印刷インキの関係上、実際とは異なる場合があります。
- 製品のデザイン、仕様等などは、予告なく変更する場合があります。

本 社：〒124-0023 東京都葛飾区東新小岩3丁目9番6号 TEL: (03) 3695-5431 / FAX: (03) 3695-5698  
 大阪支店：〒530-0054 大阪市北区南森町2-2-9(南森町八千代ビル7F) TEL: (06) 6361-4831 / FAX: (06) 6361-9360  
 e-mail: sales-tokyo@krone.co.jp URL: <https://www.krone.co.jp>

**DISCLAIMER** : ESI Technology Ltd operates a policy of continuous product development. We reserve the right to change specification without prior notice. All products manufactured by ESI Technology Ltd are calibrated using precision calibration equipment, traceable to national measurement standards.



t. +44(0)1978 262 255  
 e. sales@esi-tec.com

[www.esi-tec.com](http://www.esi-tec.com)

