

1240

UltraStable™

SPECIFICATIONS

- ◆ **PC Board Mountable Pressure Sensor**
- ◆ **0-50 mV Output**
- ◆ **Voltage Excitation**
- ◆ **Gage, Differential, and Absolute**
- ◆ **Temperature Compensated**

The 1240 is a high performance temperature compensated, piezoresistive silicon pressure sensor packaged in a dual-in-line configuration. It is intended for cost sensitive applications where excellent performance and long-term stability are required.

When using the 1240 with a fixed voltage reference and current set resistor as shown in the application schematic, a span of 50mV and 1% interchangeability can be achieved. Integral temperature compensation is provided over a range of -20°C to +85°C using laser-trimmed resistors. Absolute, differential and gage pressure ranges from 0-15 to 0-100 psi are available. Multiple lead and tube configurations are available for different applications.

Please refer to the 1210 and 1220 information on products with operating pressures less than 0-15 psi. For current excitation, please refer to the Model 1230.

FEATURES

- ◆ Dual-in-Line Package
- ◆ -20°C to +85°C Compensated Temperature Range
- ◆ ±0.1% Non Linearity
- ◆ 1.0% Interchangeable Span (provided by current set resistor)
- ◆ Solid State Reliability

APPLICATIONS

- ◆ Medical Instruments
- ◆ Airspeed Measurement
- ◆ Process Control
- ◆ Factory Automation
- ◆ Leak Detection
- ◆ Handheld Calibrators

STANDARD RANGES

Range	psia	psid	psig
0 to 2		◆	◆
0 to 5		◆	◆
0 to 15	◆	◆	◆
0 to 30	◆	◆	◆
0 to 50	◆	◆	◆
0 to 100	◆	◆	◆

PERFORMANCE SPECIFICATIONS

Supply Voltage: See application schematic

Ambient Temperature: 25°C (unless otherwise specified)

PARAMETERS	MIN	TYP	MAX	UNITS	NOTES
Span	49.5	50	50.5	mV	1
Zero Pressure Output	-2		2	mV	
Pressure Non Linearity	-0.1	±0.05	0.1	%Span	2
Pressure Hysteresis	-0.1	±0.01	0.1	%Span	
Input Resistance	2200	4000	5800	Ω	
Output Resistance		4200		Ω	
Temperature Error – Span	-0.5	±0.3	0.5	%Span	3
Temperature Error – Zero	-0.5	±0.1	0.5	%Span	3,8
Temperature Coefficient – Resistance		0.15		%/°C	3
Thermal Hysteresis – Zero		±0.05		%Span	3
Short Term Stability (Offset & Span)		±0.05		%Span	4
Long Term Stability (Offset & Span)		±0.1		%Span	5
Supply Voltage Reference		1.235		V	1
Response Time (10% to 90%)		1.0		mS	6
Output Noise (10Hz to 1kHz)		1.0		μV p-p	
Pressure Overload			3X	Rated	7
Compensated Temperature	-20		+85	°C	8
Operating Temperature	-40		+125	°C	
Storage Temperature	-50		+150	°C	
Weight			3	grams	
Solder Temperature	250°C Max 5 Sec.				
Media	Non-Corrosive Dry Gases Compatible with Silicon, Pyrex, RTV, Gold, Ceramic, Nickel, and Aluminum				

Notes

1. Refer to application schematic.
2. Best fit straight line. Non Linearity for 2 PSI is ±0.2% 5 PSI is ± 0.50%.
3. Maximum temperature error between -20°C and +85°C with respect to 25°C.
4. Short term stability over 7 days with constant current and temperature.
5. Long term stability over a one year period with constant current and temperature.
6. For a zero-to-full scale pressure step change.
7. 2X maximum for 100 psi device.
8. For pressure ranges below 15psi, compensated temperature range is 0°C to 50°C and thermal error of offset is ±1.25%.

DIMENSIONS

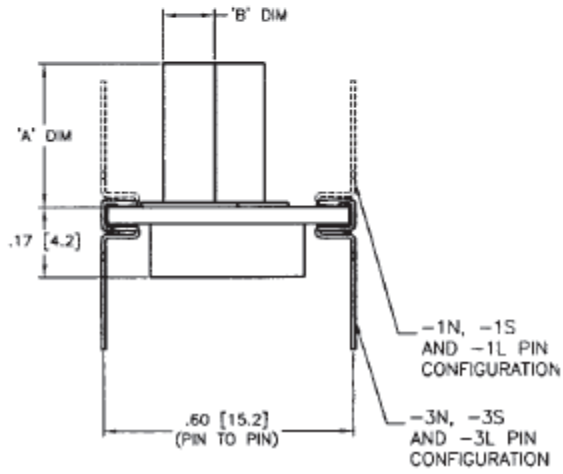
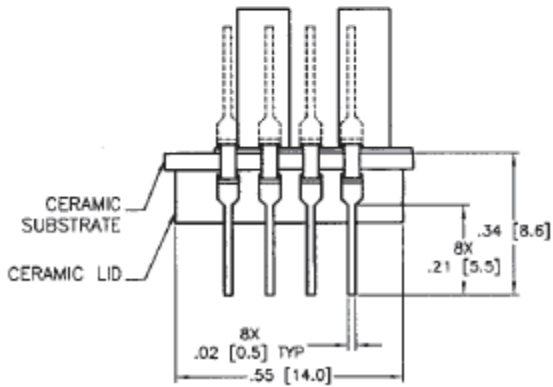
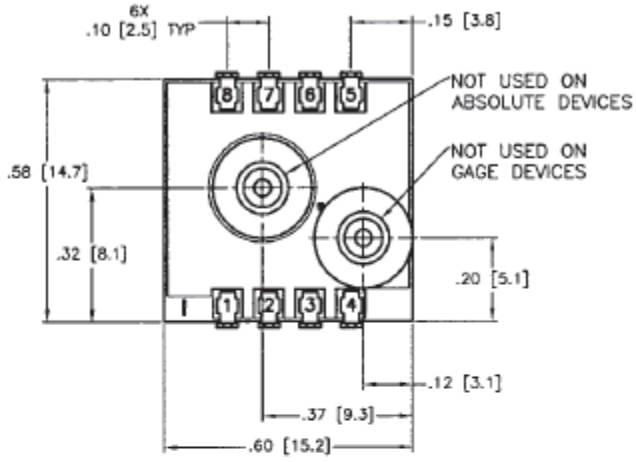

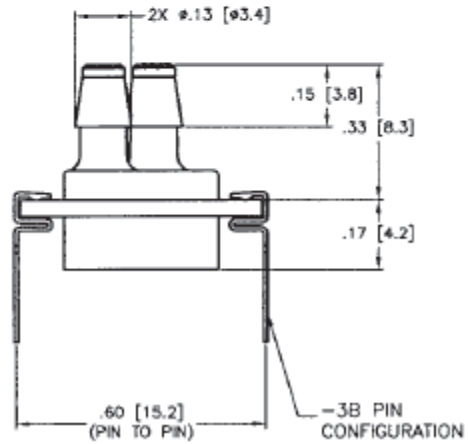
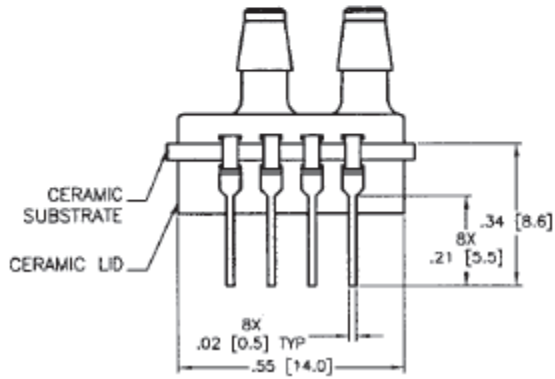
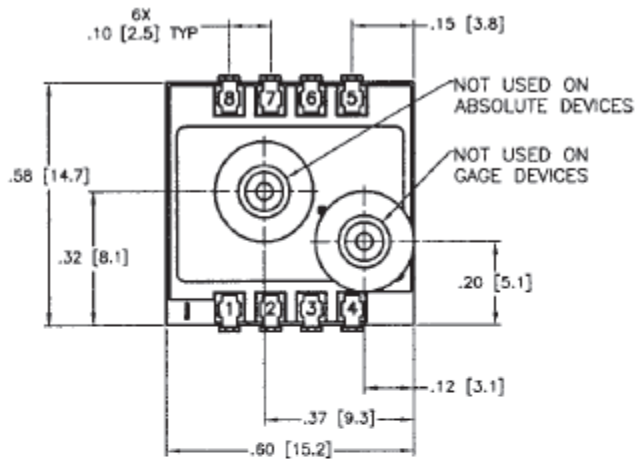

CONNECTIONS

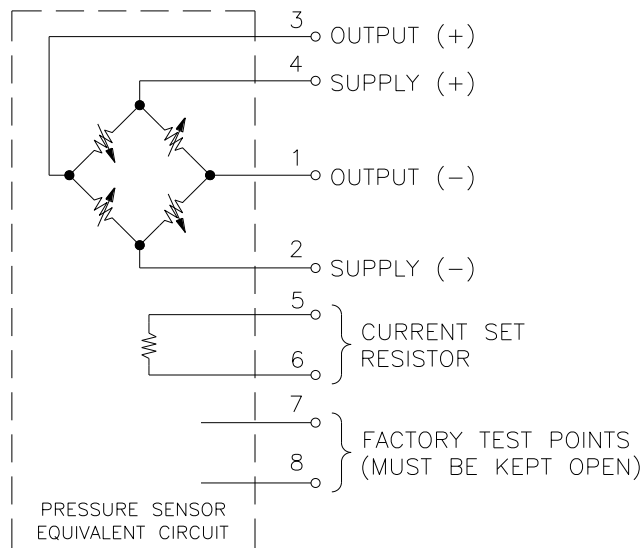

APPLICATION SCHEMATIC

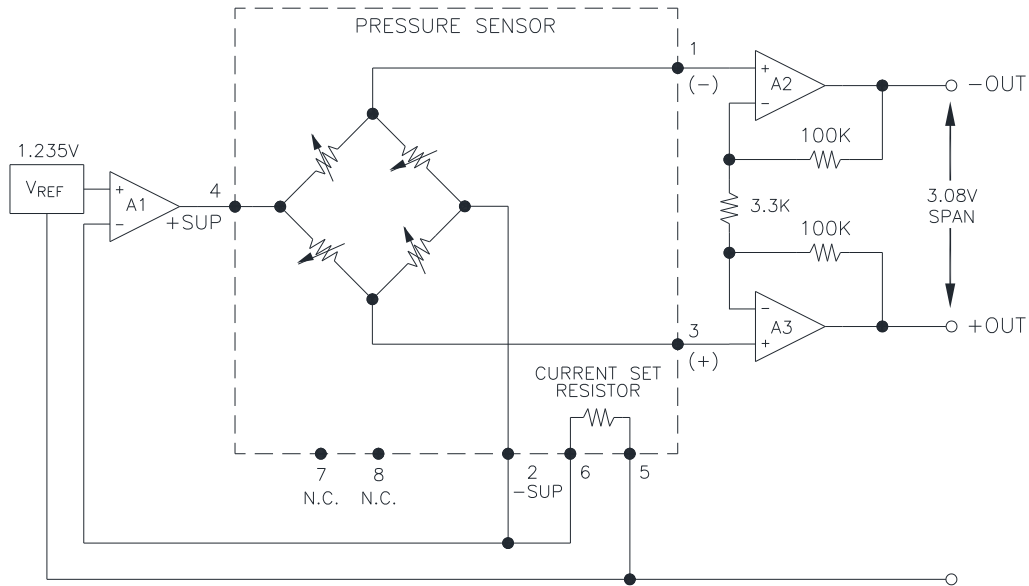

ORDERING INFORMATION

1240 Model Name	002	A	3	B
Pressure range [psi]	002 015 005 100	030		
Pressure Type	A = Absolute D = Differential		G = Gage	
Lead Configuration	1 = Same side as Vent Tube 3 = Opposite Side as vent tube			
Vent Type	L = Long Tube S = Short Tube		N = No Tube B = Barb	



株式会社 クローネ

■ カタログに掲載してある製品の色は印刷インキの関係上、実際とは異なる場合があります。
■ 製品のデザイン、仕様等などは、予告なく変更する場合があります。

本 社：〒124-0023 東京都葛飾区東新小岩3丁目9番6号 TEL: (03) 3695-5431 / FAX: (03) 3695-5698
大阪支店：〒530-0054 大阪市北区南森町2-2-9(南森町八千代ビル7F) TEL: (06) 6361-4831 / FAX: (06) 6361-9360
e-mail: sales-tokyo@krone.co.jp URL: https://www.krone.co.jp