



310 CABLE ASSEMBLY

IEPE plug and play accelerometer cable assembly. Standard cable length is 120 inches with 10-32 coaxial connector at each end. Mates with accelerometer models 7100A, 7104A, 7105A, 7108A, 7130A.

FEATURES

- PFA Jacket
- PFA Insulated #30 AWG Conductors
- SPC Braided Shield
- 2 x 10-32 Coaxial Connector
- -55°C to +200°C Temp Range

APPLICATIONS

- IEPE Accelerometers
- Vibration Monitoring
- General Purpose
- Shock Monitoring
- Laboratory Testing

DIMENSIONS

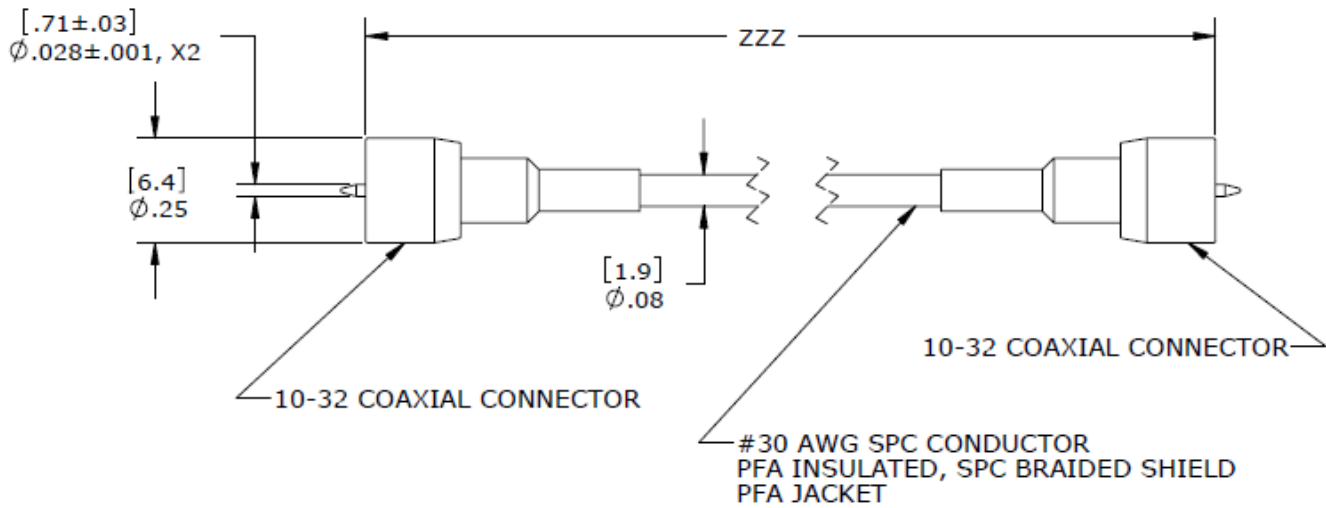

ORDERING INFORMATION

310

- ZZZ

Cable length

120=120 inches (10ft)
 240=240 inches (20ft)
 360=360 inches (30ft)

Example; 310-120

Model 310 cable, 120inch cable length (standard length typically in stock)



株式会社 クローネ

■カタログに掲載してある製品の色は印刷インキの関係上、実際とは異なる場合があります。
 ■製品のデザイン、仕様などは、予告なく変更する場合があります。

本 社：〒124-0023 東京都葛飾区東新小岩3丁目9番6号 TEL: (03) 3695-5431 / FAX: (03) 3695-5698
 大阪支店：〒530-0054 大阪市北区南森町2-2-9(南森町八千代ビル7F) TEL: (06) 6361-4831 / FAX: (06) 6361-9360
 e-mail: sales-tokyo@krone.co.jp URL: <https://www.krone.co.jp>

te.com/sensorsolutions

TE Connectivity, TE, and the TE connectivity (logo) are trademarks of the TE Connectivity Ltd. family of companies. Other logos, products and/or company names referred to herein may be trademarks of their respective owners.

The information given herein, including drawings, illustrations and schematics which are intended for illustration purposes only, is believed to be reliable. However, TE Connectivity makes no warranties as to its accuracy or completeness and disclaims any liability in connection with its use. TE Connectivity's obligations shall only be as set forth in TE Connectivity's Standard Terms and Conditions of Sale for this product and in no case will TE Connectivity be liable for any incidental, indirect or consequential damages arising out of the sale, resale, use or misuse of the product. Users of TE Connectivity products should make their own evaluation to determine the suitability of each such product for the specific application.

© 2018 TE Connectivity Ltd. family of companies All Rights Reserved.