

MODEL 7132A & 7132B ACCELEROMETER



7132A Pictured



DIMENSIONS

7132A Dimensions

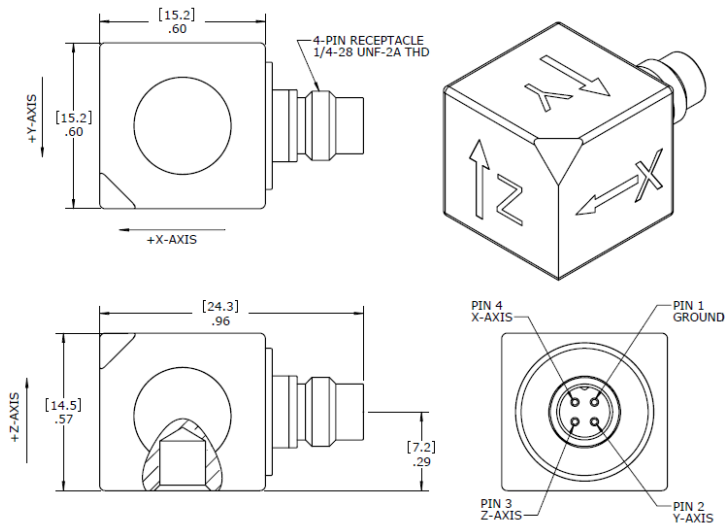

7132B Dimensions

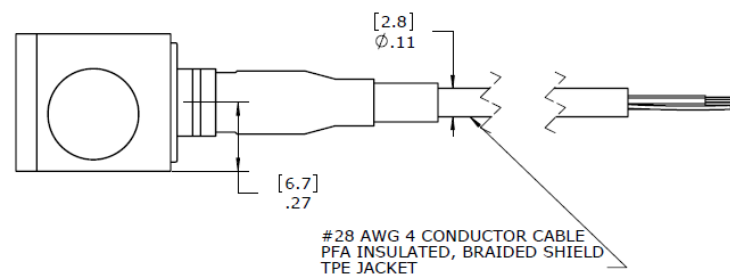

SPECIFICATIONS

- ◆ Triaxial IEPE Accelerometer
- ◆ Miniature Cube
- ◆ Hermetically Sealed, Titanium
- ◆ $\pm 10g$ to $\pm 2000g$ Dynamic Ranges

The Model 7132A is a miniature triaxial IEPE accelerometer available in $\pm 10g$ to $\pm 2000g$ dynamic ranges. The accelerometer features a hermetically sealed titanium construction with a 4-pin Microtech connector interface. The model 7132A incorporates stable piezo-ceramic crystals in annular shear mode which provide a flat frequency response up to $>12kHz$. The model 7132B offers identical performance with an integral cable option.

FEATURES

- ◆ $-55^{\circ}C$ to $+125^{\circ}C$ Operating Range
- ◆ Wide bandwidth up to 12kHz
- ◆ Adhesive Mounting
- ◆ Miniature Triaxial
- ◆ Annular Shear Mode Crystals
- ◆ Stable Temperature Response

APPLICATIONS

- ◆ Vibration & Shock Monitoring
- ◆ Laboratory Testing
- ◆ Modal Applications
- ◆ High Frequency Applications
- ◆ General Purpose Usage
- ◆ Stress Screening

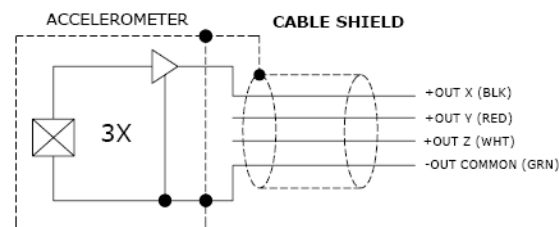

MODEL 7132A & 7132B ACCELEROMETER

PERFORMANCE SPECIFICATIONS

All values are typical at +24°C, 80Hz and 4mA excitation unless otherwise stated. Measurement Specialties reserves the right to update and change these specifications without notice.

Parameters

DYNAMIC

	±10	±50	±100	±500	±2000	Notes
Range (g)	±10	±50	±100	±500	±2000	
Sensitivity (mV/g)	500	100	50	10	2.5	±10%
Frequency Response (Hz)	2-6000	1-7000	1-7000	1-8000	1-10000	±10%
Frequency Response (Hz)	1.5-8000	0.4-9000	0.4-9000	0.4-10000	0.4-12000	±2dB
Natural Frequency (Hz)	37000	37000	37000	37000	42000	
Non-Linearity (%FSO)	±1	±1	±1	±1	±1	
Transverse Sensitivity (%)	<5	<5	<5	<5	<5	
Shock Limit (g)	5000	5000	5000	5000	5000	
Residual Noise (g RMS)	0.0003	0.0005	0.0006	0.001	0.0025	Broadband 1Hz to 10kHz

ELECTRICAL

Compliance Voltage (Vdc)	18 to 30	
Excitation Current (mA)	2 to 10	
Bias Voltage (Vdc)	8 to 12	Room Temperature
Bias Voltage (Vdc)	6 to 13	-55 to +125°C
Output Impedance (Ω)	<100	
Full Scale Output Voltage (V)	±5	
Discharge Time Constant (sec)	0.8 to 1.2	
Ground Isolation	Case Grounded	

ENVIRONMENTAL

Temperature Response (%)	See Typical Temperature Response Curve
Operating Temperature (°C)	-55 to +125
Storage Temperature (°C)	-55 to +125
Humidity	Hermetically Sealed, IP67

PHYSICAL

Sensing Element	Ceramic (shear mode)
Case Material	Titanium
Electrical Connector	7132A; 4-Pin Receptacle 7132B; 4x #28 AWG Conductors, Braided Shield, TPE Jacket
Weight	15grams (50g-2000g ranges), 20grams (10g range)
Mounting	Adhesive (stud mount option)

Calibration supplied: CS-FREQ-0100 NIST Traceable Amplitude Calibration from 20Hz to ±2dB Frequency Response Limit

Optional accessories: 315-XXX Cable Assembly, 4-pin 1/4-28 to 3x BNC (XXX designates length in inches, 10ft standard)
161A 4-Channel PE & IEPE Signal Conditioner
AC-A03530 Magnetic Mounting Adaptor (for -02 thread option)

The information in this sheet has been carefully reviewed and is believed to be accurate; however, no responsibility is assumed for inaccuracies. Furthermore, this information does not convey to the purchaser of such devices any license under the patent rights to the manufacturer. Measurement Specialties, Inc. reserves the right to make changes without further notice to any product herein. Measurement Specialties, Inc. makes no warranty, representation or guarantee regarding the suitability of its product for any particular purpose, nor does Measurement Specialties, Inc. assume any liability arising out of the application or use of any product or circuit and specifically disclaims any and all liability, including without limitation consequential or incidental damages. Typical parameters can and do vary in different applications. All operating parameters must be validated for each customer application by customer's technical experts. Measurement Specialties, Inc. does not convey any license under its patent rights nor the rights of others.

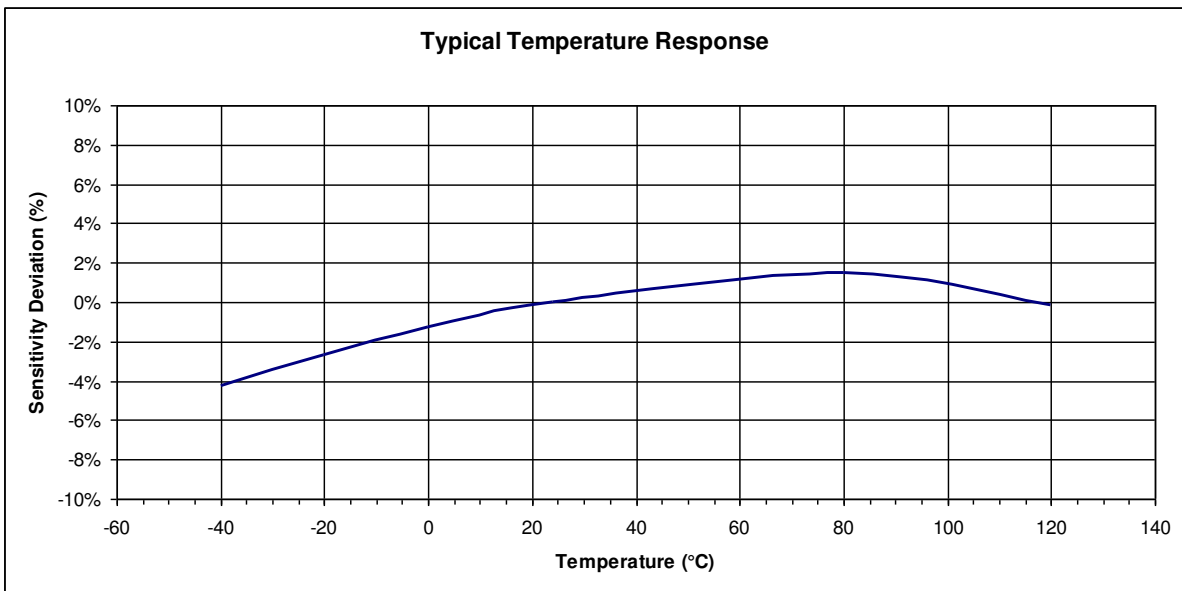
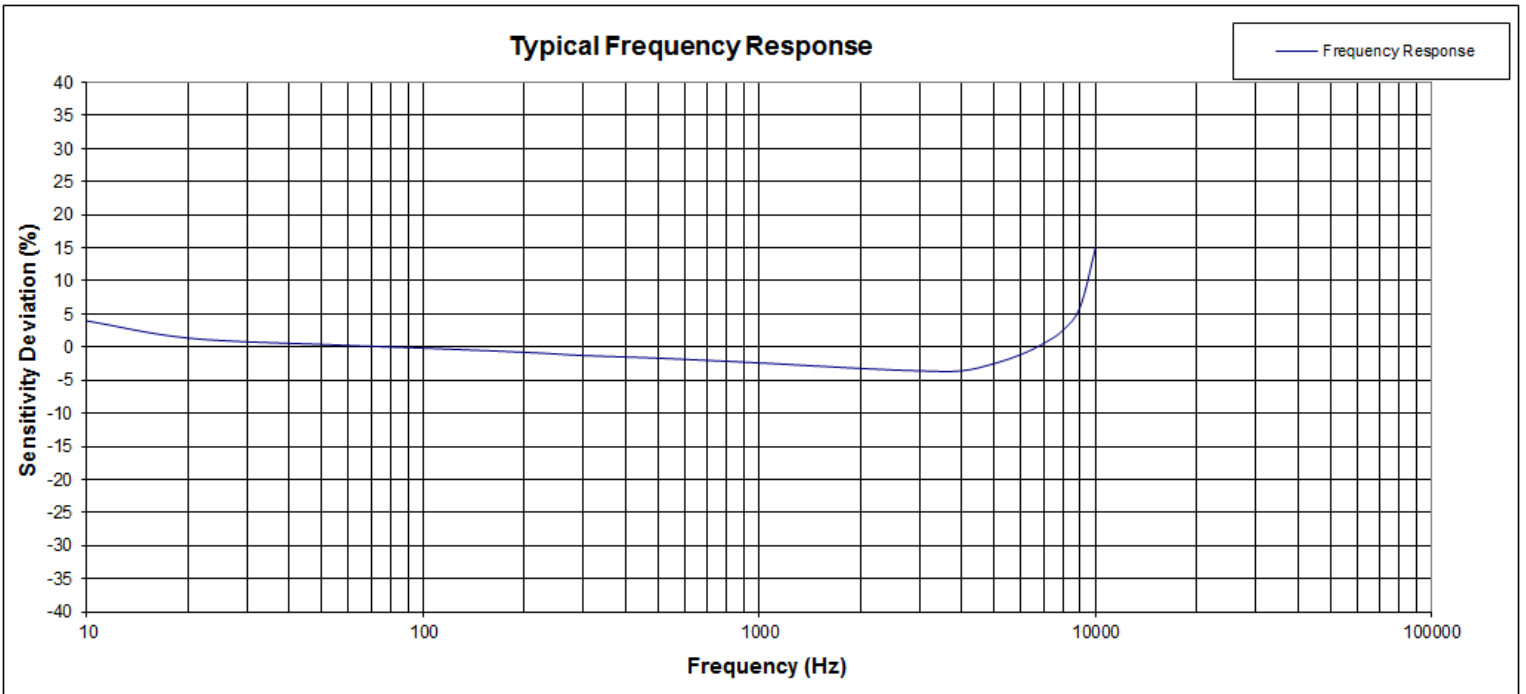

ORDERING INFORMATION

PART NUMBERING Model Number+Range

7132A-GGGG-XX

| | | Optional Thread Dash Number

| | Range (0050 is 50g)

| Connection Option (A for 4-pin Microtech, B for integral cable)

Dash Number

-01

-02

-03

Thread Options

M5 x 0.8 6g

#10-32 UNF-2B

Case Isolated

Example: 7132A-0050

Model 7132A, 4-Pin Microtech Connector, 50g Range



株式会社 クローネ

■カタログに掲載してある製品の色は印刷インキの関係上、実際とは異なる場合があります。
■製品のデザイン、仕様等などは、予告なく変更する場合があります。

本 社：〒124-0023 東京都葛飾区東新小岩3丁目9番6号 TEL: (03) 3695-5431 / FAX: (03) 3695-5698
大阪支店：〒530-0054 大阪市北区南森町2-2-9(南森町八千代ビル7F) TEL: (06) 6361-4831 / FAX: (06) 6361-9360
e-mail: sales-tokyo@krone.co.jp URL: https://www.krone.co.jp

TE.com/sensorsolutions

Measurement Specialties, Inc., a TE Connectivity company.

Measurement Specialties, TE Connectivity, TE Connectivity (logo) and EVERY CONNECTION COUNTS are trademarks. All other logos, products and/or company names referred to herein might be trademarks of their respective owners.

The information given herein, including drawings, illustrations and schematics which are intended for illustration purposes only, is believed to be reliable. However, TE Connectivity makes no warranties as to its accuracy or completeness and disclaims any liability in connection with its use. TE Connectivity's obligations shall only be as set forth in TE Connectivity's Standard Terms and Conditions of Sale for this product and in no case will TE Connectivity be liable for any incidental, indirect or consequential damages arising out of the sale, resale, use or misuse of the product. Users of TE Connectivity products should make their own evaluation to determine the suitability of each such product for the specific application.

© 2015 TE Connectivity Ltd. family of companies All Rights Reserved.