



## FCA7300

### Torque/Speed/Velocity for Steering Wheel

#### SPECIFICATIONS

- ◆ **On-Board Electronics**
- ◆ **Five Simultaneous Analog Outputs**
  - 2 Torques**
  - 2 Angles**
  - 1 Angular Velocity**
- ◆ **Built-In Shunt Calibration Function**
- ◆ **Steer ability maintained at Rupture**
- ◆ **Unique Remote Data Acquisition trigger feature**

The **FCA7300** steering wheels sensors are designed for automotive testing and provide an “all-in” measurement.

This generation of transducers incorporates numerous technological functions, such as:

- ◆ Angle reset, torque calibration
- ◆ A Start trigger signal to the remote data acquisition system.
- ◆ Optical coder processing to prevent the need for external TTL electronics
- ◆ Five simultaneous analogue output signals
- ◆ Suppression of the bearing friction influence on torque, allowing high accuracy for low torque measurements
- ◆ Low profile design retains the same driving conditions as with standard steering wheels.
- ◆ The sensor assembly can be operated:
  - The sensor can be screwed on shaft, see drawing page 3.
  - Easily mounted on any road vehicle by optional flanges, please consult factory.
- ◆ Optional steering stops adjustable between  $\pm 15^\circ$  to  $\pm 165^\circ$  are available. These stops fold automatically for safety.

#### FEATURES

- ◆ Universal – fits all road vehicles
- ◆ Rapidly Installed via mounting adapters
- ◆ 10x FS Torque overload protection
- ◆ Highest accuracy available on the market
- ◆ Low fitting depth
- ◆ Universal - fits all road vehicles
- ◆ Rapidly installed via mounting adapters
- ◆ 3000 point optical coder for angle/velocity measurement
- ◆ Angular /velocity signals processed Internally to give analogue outputs -
- ◆ No need for external ttl electronics
- ◆ 10 x F.S. torque overload protection
- ◆ Optional adjustable steering stops available (self-folding for safety)

#### APPLICATIONS

- ◆ Automotive design & test
- ◆ Trucks maintenance testing

## GENERAL FEATURES

The FCA 7300 series of measurement steering wheels are the most accurate available on the market today. This new generation of transducers incorporates numerous technological innovations, such as :

Full on-board conditioning electronics, with built-in angle reset, torque calibration function and a facility to send a start trigger signal to the remote data acquisition system.

Optical coder processing electronics are built-in - there is no need for external TTL electronics

Five simultaneous analogue output signals, two torque channels, two angle channels and one angular velocity channel

Bearing friction influence on the torque measurement has been eliminated, allowing high accuracy low torque measurements

Low profile design retains the same driving conditions as with standard steering wheels.

Easily mounted on any road vehicle by means of flanges; no disassembly of the steering column is required.

Optional steering stops adjustable between  $\pm 15^\circ$  to  $\pm 165^\circ$  are available. These stops fold automatically for safety: there is no need for the driver to hit a panic button.



Mounting principle of transducer on steering column - no disassembly of column is required.  
Adapters are not supplied

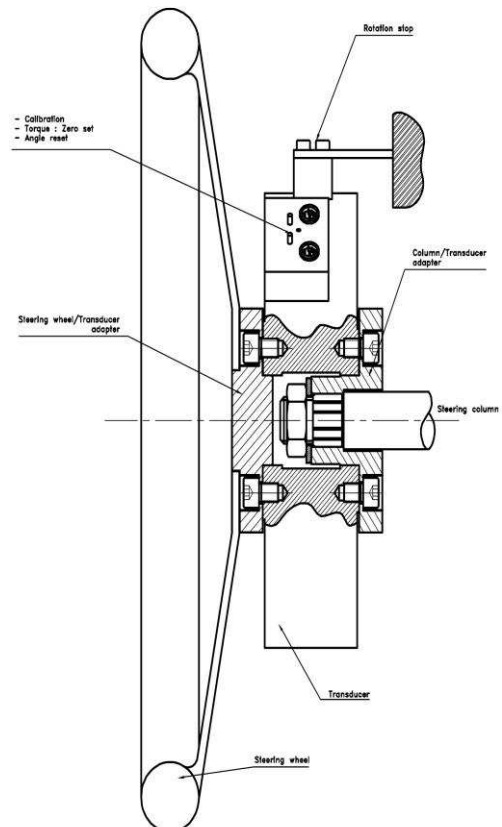

**FCA7300**

Torque/Speed/Velocity on Steering Wheel

**PERFORMANCE SPECIFICATIONS (typical values at 23±3°C)**

<b>CAPTEUR TYPE</b> <i>MODEL SENSOR</i>	<b>FCA7300</b>	Ref. FCA7300-xxx_Rev B
<b>UTILISATION</b> <i>DESCRIPTION</i>	Couplemètre dynamique + Mesure d'angle et vitesse <i>Dynamic torquemeter + Angle and speed measuring</i>	570* 577* 670* 673* 862*

<b>ETENDUE DE MESURE</b> <i>RANGE</i>	___Nm/___Nm - ±___°/±___° - 1080°/s	
<b>SURCHARGE ADMISSIBLE</b> <i>OVERANGE</i>	Voir Tableau See Table	
<b>TENSION D'ALIMENTATION</b> <i>EXCITATION</i>	10 / 28 Vcc 10 / 28 Vdc	
<b>SIGNAL A L'ETENDUE DE MESURE</b> <i>SIGNAL OUTPUT AT FULL SCALE</i>	±10V / 10V (Pour couples et angles / pour vitesse) ±10V / 10V (For torques and angles / for velocity)	
<b>DESEQUILIBRE</b> <i>OFFSET</i>	0V ±0.5V 0V ±0.5V	
<b>LINEARITE + HYSTERESIS</b> <i>LINEARITY + HYSTERESIS</i>	< ± 0.15% de l'EM <±0.3% à partir de 100Nm < ± 0.15% de l'EM <±0.3% after 100Nm	
<b>ISOLEMENT à 50Vcc</b> <i>INSULATION at 50 Vdc</i>	> 100 MΩ > 100 MΩ	
<b>INDICE DE PROTECTION</b> <i>PROTECTION</i>	IP50	
<b>PLAGE D'UTILISATION EN TEMPERATURE (OTR)</b> <i>OPERATING TEMPERATURE RANGE (OTR)</i>	-20°C à +80°C -20°C to +80°C	
<b>PLAGE DE COMPENSATION EN TEMPERATURE (CTR)</b> <i>COMPENSATED TEMPERATURE RANGE (CTR)</i>	0°C à +60°C 0°C to +60°C	
<b>DERIVE DE ZERO DANS LA PLAGE COMPENSEE</b> <i>ZERO SHIFT WITHIN CTR</i>	< 0.5 % de l'étendue de mesure / 50°C < 0.5 % full scale / 50°C	
<b>DERIVE DE SENSIBILITE DANS LA PLAGE COMPENSEE</b> <i>SENSITIVITY SHIFT WITHIN CTR</i>	< 1 % de la valeur lue / 50°C < 1 % of reading / 50°C	
<b>SORTIE ELECTRIQUE</b> <i>ELECTRICAL OUTPUT</i>	Embases LEMO 4b et 6b 4p & 6p LEMO receptacles	
<b>FICHE MOBILE</b> <i>MATING CONNECTOR</i>	Oui Yes	
<b>TYPE ET LONGUEUR DE CABLE</b> <i>CABLE OUTPUT</i>		

**OBSERVATIONS :** \* Voir plan joint pour les étendues de mesures du FCA7300  
**NOTES :** \* See attached drawing for configure FCA7300 ranges

EM / Range (Nm)	10	20	30	40	50	60	80	100	150	200	250
Surch./Overrange (Nm)	100	200	300	300	300	300	120	150	225	300	300

La société se réserve le droit de modifier sans préavis les cotes et spécifications annoncées

# FCA7300

Torque/Speed/Velocity on Steering Wheel

## DIMENSIONS

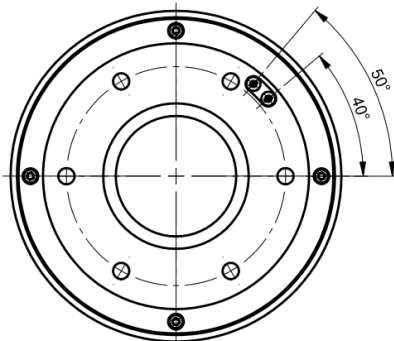
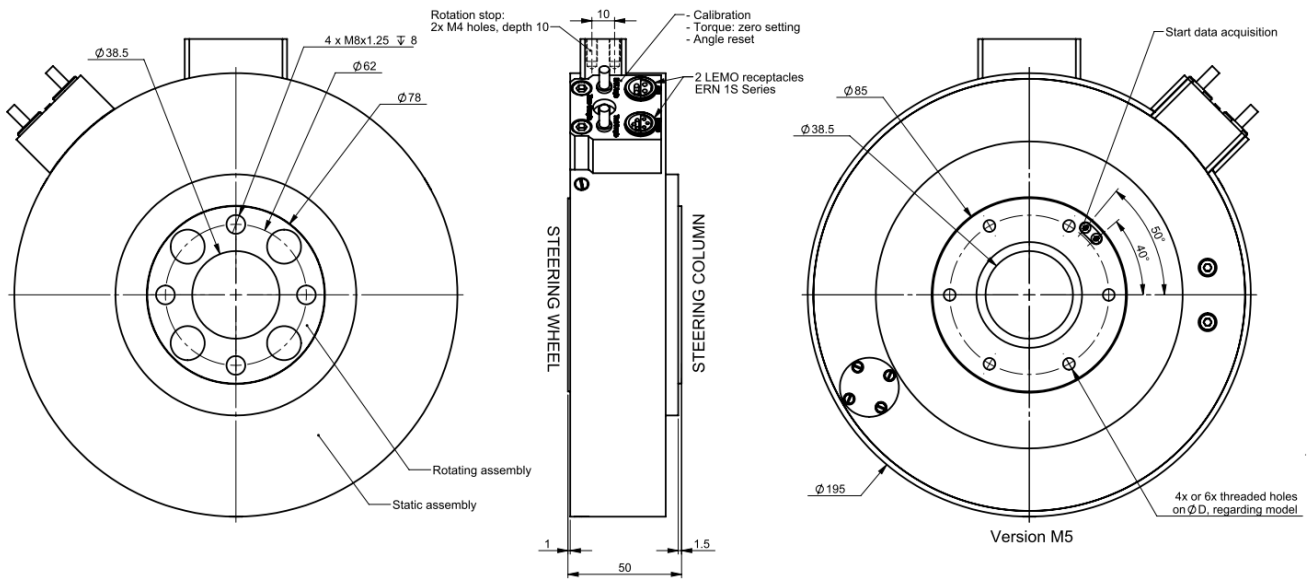

M6 Version

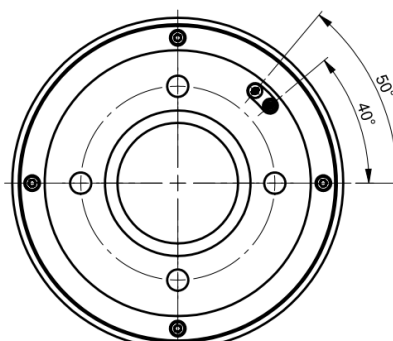

M8 Version

## FCA7300-xxx-xx/xxx-xxx/xxxx

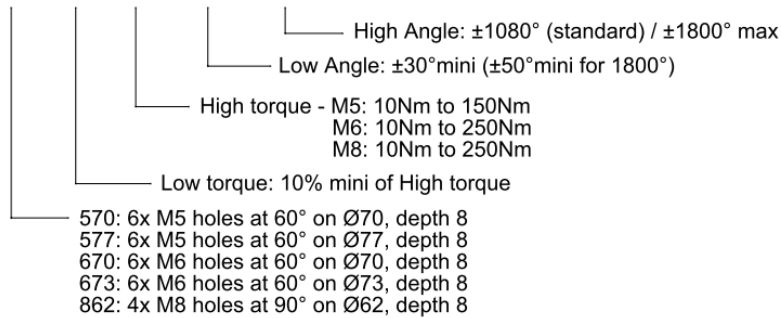

**ANGULAR STEERING STOPS**

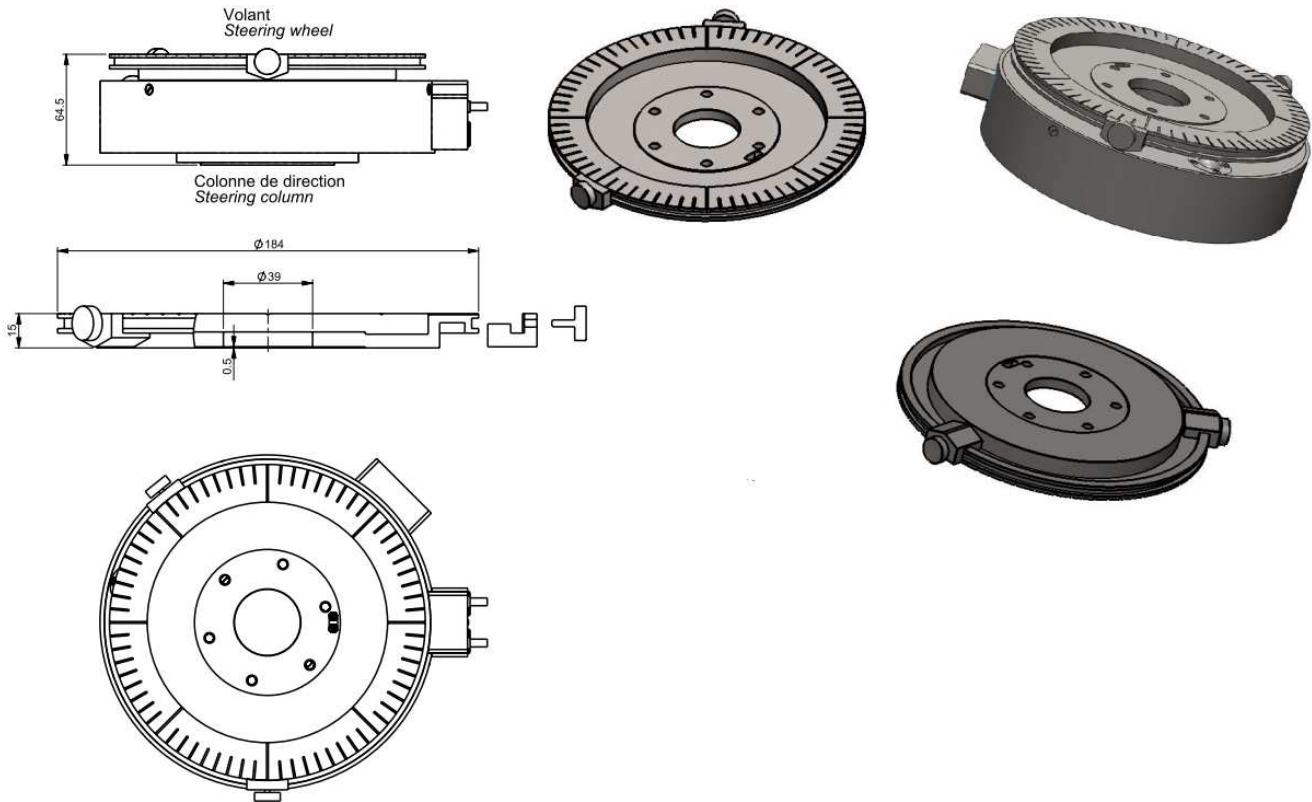

Designation	Part Number
FCA7300-570-STEERING STOPS	EFCA7-X-X00001
FCA7300-577-STEERING STOPS	EFCA7-X-X00002
FCA7300-670-STEERING STOPS	EFCA7-X-X00003
FCA7300-673-STEERING STOPS	EFCA7-X-X00004
FCA7300-862-STEERING STOPS	EFCA7-X-X00005

Plage de réglage:  $\pm 15^\circ$  à  $\pm 165^\circ$   
 Pour des raisons de sécurité, les butées mécaniques se déconnectent lorsque le couple prédéfini est atteint

*Adjustable steering stops:  $\pm 15^\circ$  to  $\pm 165^\circ$   
 For safety reasons, steering stops automatically set off when defined torque is reached*

STEERING WHEEL ADAPTER (Ø330 to 400)

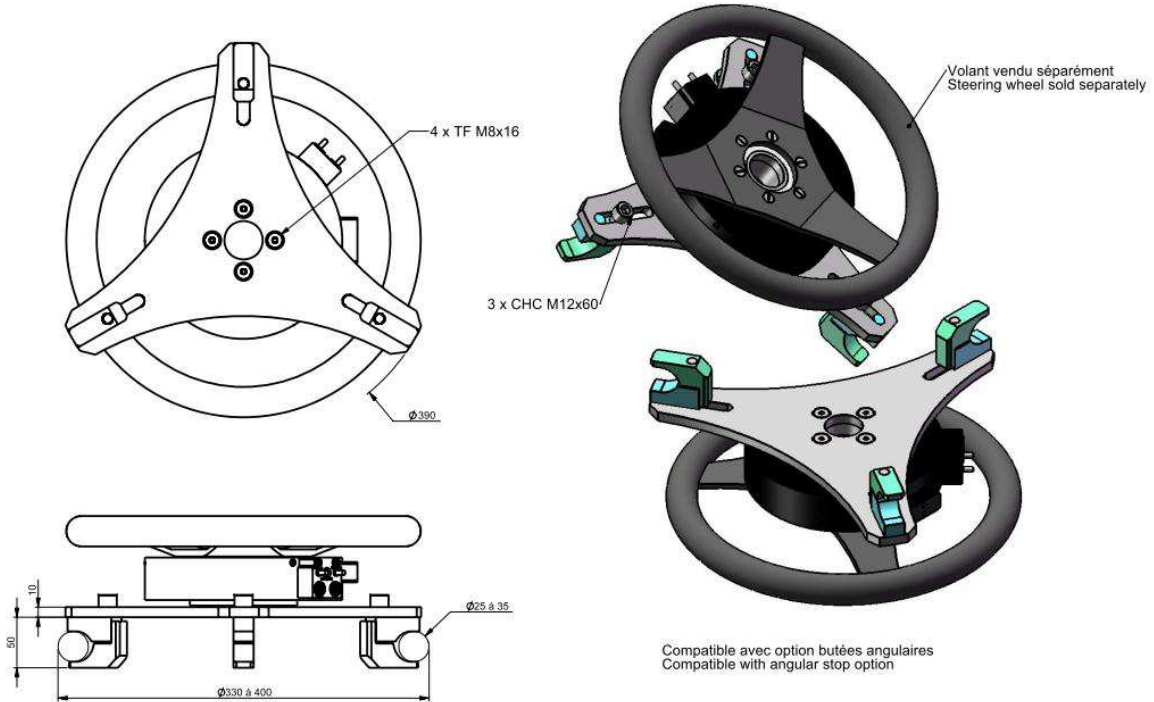

STEERING WHEEL ADAPTER (Ø400 to 530)

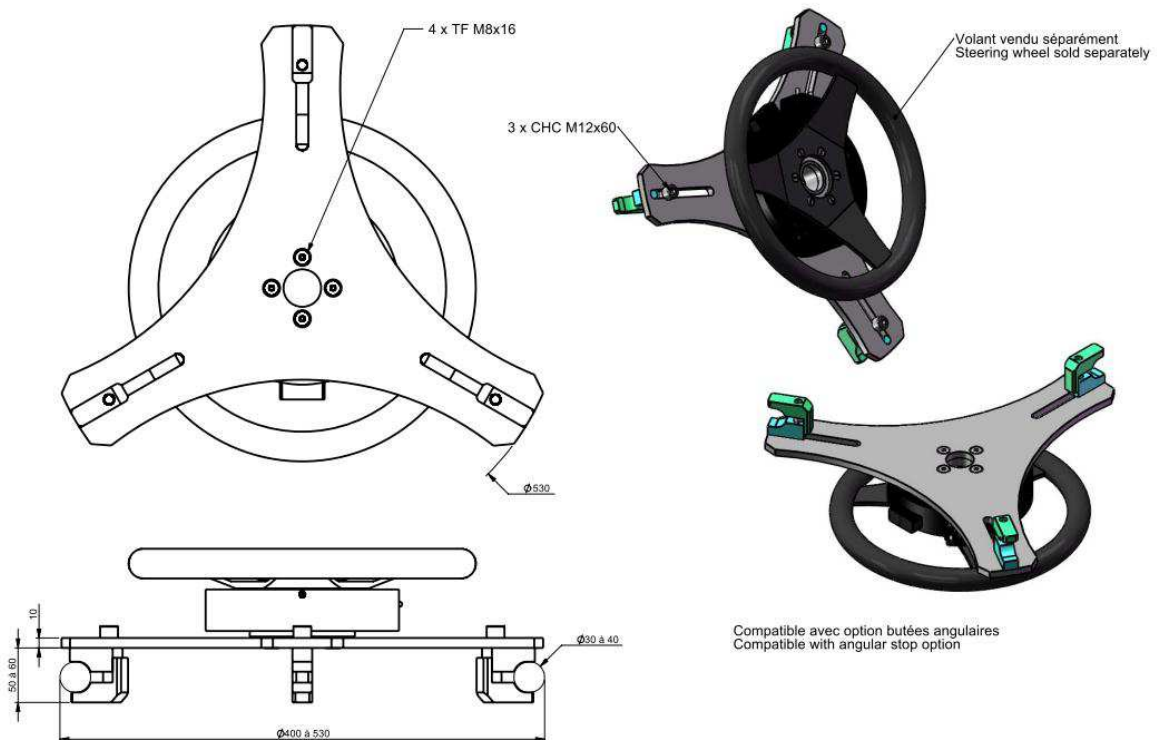

# FCA7300

Torque/Speed/Velocity on Steering Wheel

## FCA7300 ASSEMBLY & OPTIONS

SENSOR		AVAILABLE OPTIONS				
Max FSO	Steering wheel interface fixation	Column interface	Steering wheel S or L adapter	Angular steering stops	Spacer sensor / steering wheel (only with angular steering stops)	Steering wheel supplied
150 Nm	6xM5 on Ø70	Yes To be defined following customer interface column	Yes S: Ø 330 to 400mm PN: EFCA-7-X-X00006 L: Ø 400 to 530mm PN: EFCA-7-X-X00007	Yes PN: EFCA-7-X-X00001	570 / 570 PN: ZFN7300064	NO
150 Nm	6xM5 on Ø77			Yes PN: EFCA-7-X-X00002	577 / 577 PN: ZFN7300065	NO
<b>250 Nm</b>	<b>6xM6 on Ø70</b>			<b>Yes</b> PN: EFCA-7-X-X00003	<b>670 / 670</b> PN: ZFN7300057	<b>Yes (Ø 350 and 380mm)</b>
250 Nm	6xM6 on Ø73			Yes PN: EFCA-7-X-X00004	673 / 673 PN: ZFN7300066	NO
250 Nm	4xM8 on Ø62			Yes PN: EFCA-7-X-X00005	862 / 862 PN: ZFN7300067	NO
Other specific request	Other specific request					

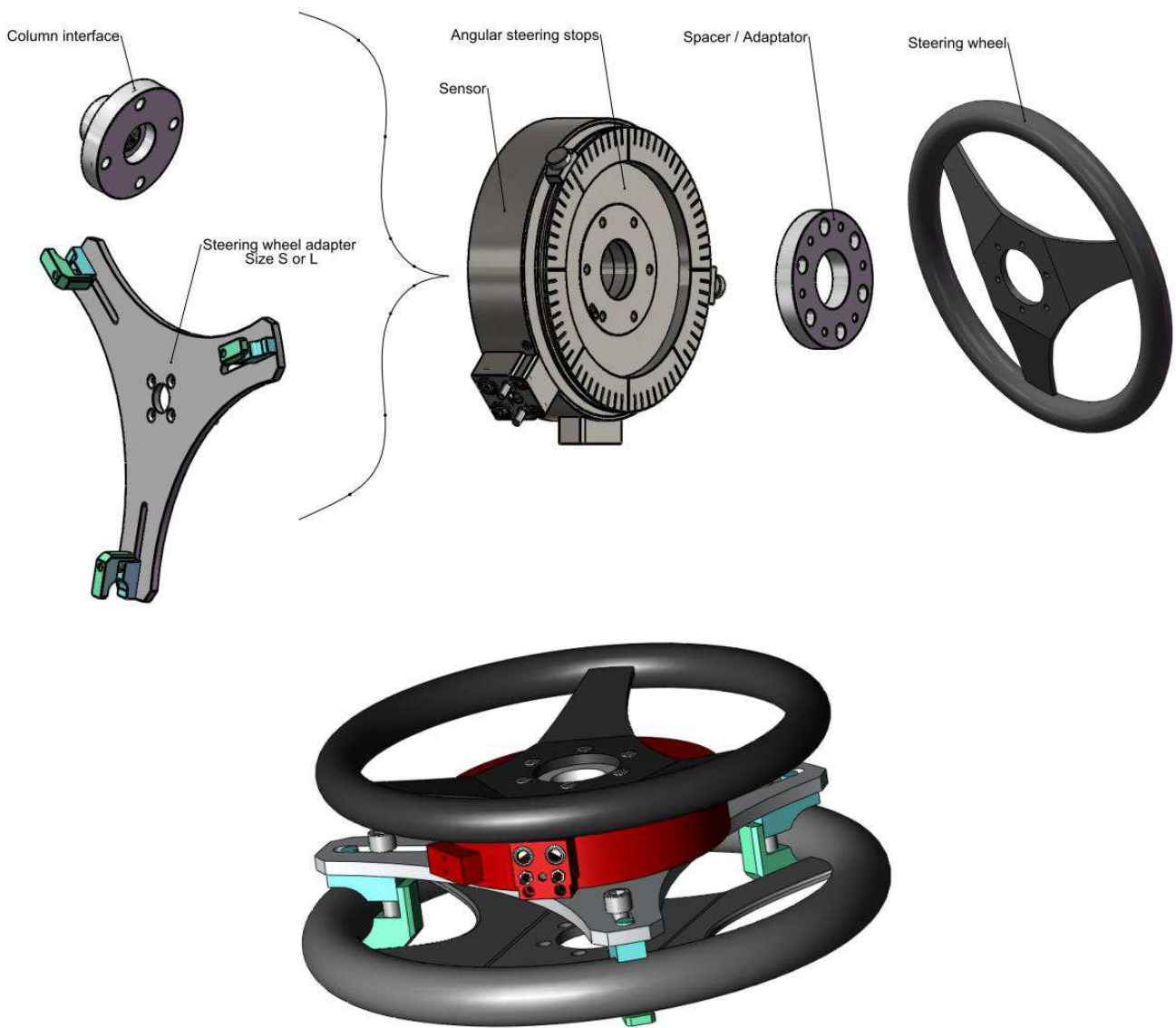

**ORDERING INFORMATION**

**FCA7300-xxx-xx/xxx-xxx/xxxx**

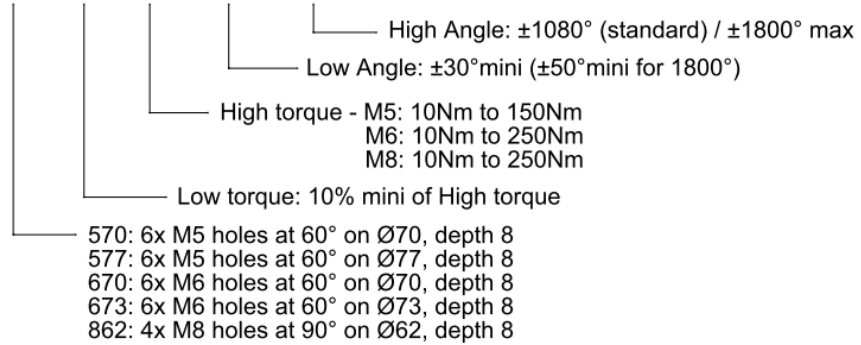

株式会社 **クローネ**

■カタログに掲載してある製品の色は印刷インキの関係上、実際とは異なる場合があります。  
■製品のデザイン、仕様等などは、予告なく変更する場合があります。

本 社：〒124-0023 東京都葛飾区東新小岩3丁目9番6号 TEL: (03) 3695-5431 / FAX: (03) 3695-5698  
大阪支店：〒530-0054 大阪市北区南森町2-2-9(南森町八千代ビル7F) TEL: (06) 6361-4831 / FAX: (06) 6361-9360  
e-mail: sales-tokyo@krone.co.jp URL: https://www.krone.co.jp

**TE.com/sensorsolutions**

Measurement Specialties, Inc., a TE Connectivity company.

Measurement Specialties, TE Connectivity, TE Connectivity (logo) and EVERY CONNECTION COUNTS are trademarks. All other logos, products and/or company names referred to herein might be trademarks of their respective owners.

The information given herein, including drawings, illustrations and schematics which are intended for illustration purposes only, is believed to be reliable. However, TE Connectivity makes no warranties as to its accuracy or completeness and disclaims any liability in connection with its use. TE Connectivity's obligations shall only be as set forth in TE Connectivity's Standard Terms and Conditions of Sale for this product and in no case will TE Connectivity be liable for any incidental, indirect or consequential damages arising out of the sale, resale, use or misuse of the product. Users of TE Connectivity products should make their own evaluation to determine the suitability of each such product for the specific application.

© 2015 TE Connectivity Ltd. family of companies All Rights Reserved.